

# Lever Chain Hoists

Black & Galvanized Load Chain



- Complies with ASME B30.21
- Automatic, Double-Pawl, Braking System
- Grade 80, High-Quality, Heat Treated, Steel Load Chain
- Forged Steel Hooks
- Up to 6 Tons
- Standard 10' or 20' lift
- Zinc Chain and Custom Lift Heights Available Upon Request



# Lever Chain Hoists

Black & Galvanized Load Chain

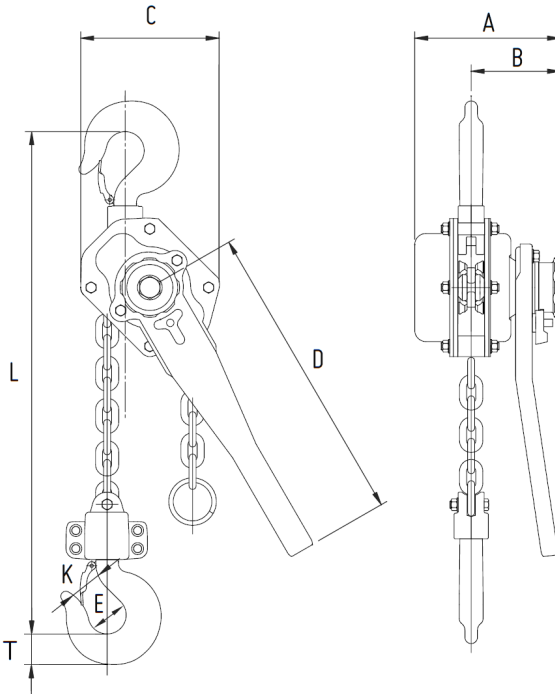

Product Code	Capacity	Standard Lift	Load Chain Ø x Chain Fall Lines	Net Weight
	tons	feet	mm	lbs
LH075-10	3/4	10	Ø 6 x 1	18
LH075-20	3/4	20	Ø 6 x 1	23
LH15-10	1.5	10	Ø 7.1 x 1	26
LH15-20	1.5	20	Ø 7.1 x 1	33
LH30-10	3	10	Ø 10 x 1	46
LH30-20	3	20	Ø 10 x 1	60
LH60-10	6	10	Ø 10 x 2	77
LH60-20	6	20	Ø 10 x 2	106

\*6 Ton Lever Hoist only available in black chain

Product Code	Capacity	Headroom (L)	A	B	C	D	E	K	T
	tons	inches	inches	inches	inches	inches	inches	inches	inches
LH075-10	3/4	12.6	5.83	3.54	5.35	11.02	1.57	1.06	0.8
LH075-20	3/4	12.6	5.83	3.54	5.35	11.02	1.57	1.06	0.8
LH15-10	1.5	14.96	6.77	3.86	6.3	16.14	1.73	1.34	1.14
LH15-20	1.5	14.96	6.77	3.86	6.3	16.14	1.73	1.34	1.14
LH30-10	3	18.9	7.87	4.53	7.09	16.14	1.97	1.5	1.73
LH30-20	3	18.9	7.87	4.53	7.09	16.14	1.97	1.5	1.73
LH60-10	6	23.62	7.87	4.53	9.25	16.14	2.52	1.89	2.09
LH60-20	6	23.62	7.87	4.53	9.25	16.14	2.52	1.89	2.09

\*6 Ton Lever Hoist only available in black chain