

HOIST DUAL SPEED

Key Specifications:

- CONTROL VOLTAGE: 48V
- 20 FT. LIFT HEIGHT
- LIFTING SPEED: 10/31 FT./MIN
- TROLLEY SPEED: 43.3 / 14.4

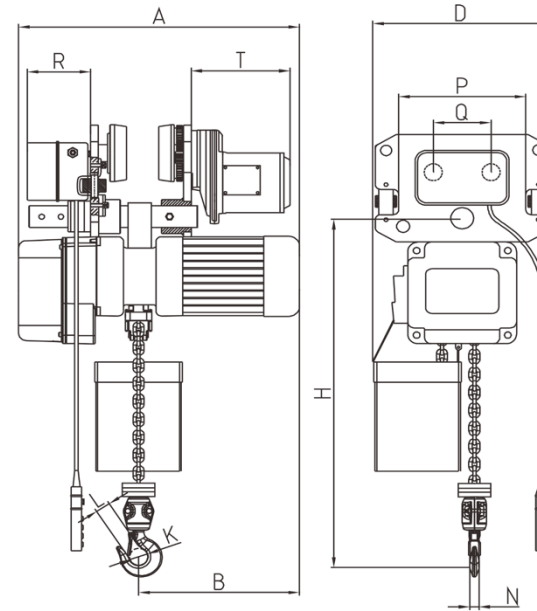

Product Code:	Cap.	Lift Height	Lifting Speed	Trolley Speed	Motor Power	Power Supply	Control Voltage	Load Chain Size Ø	Chain Fall Lines	Pendant Cord Length	Hoist Amp Draws	Hoist Amp Draws	Trolley Amp Draws	Trolley Amp Draws	Total Net Weight:
	Tons	Ft	Ft/Min	Ft/Min	HP.	Volts (3-Phase) 60Hz	Volts	mm		Ft.	@460v	@230v	@460v	@230v	Lbs.
HHBD005SK-01D + WP005D	1/2	20	10.3 / 31	43.3 / 14.4	1.2	230 or 460	110	6.3	1	17	2.6	3.6	1.5	3	192

Product Code:	Cap.	Head Room (C)	A	B	D	E	K	L	N	O	R	T
	Tons	Inches	Inches	Inches	Inches	Inches	Inches	Inches	Inches	Inches	Inches	Inches
HHBD005SK-01D + WP005D	1/2	17.71	24.88	13	12.5	3.7	1.57	1.22	0.75	4.33	6	9.5