



BISON
LIFTING EQUIPMENT

ELECTRIC CHAIN HOIST USER MANUAL

**THIS OPERATOR'S MANUAL IS EFFECTIVE
FOR THE FOLLOWING MODELS:**

**1 – 5 TON CAPACITY
3 – PHASE 230V/ 460V
SINGLE & DUAL SPEED MODELS**

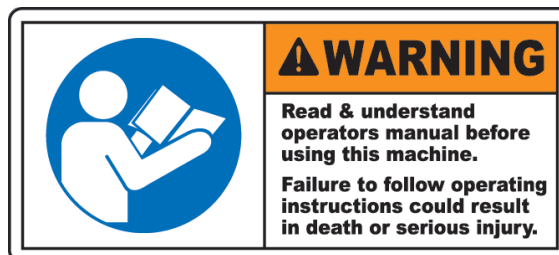
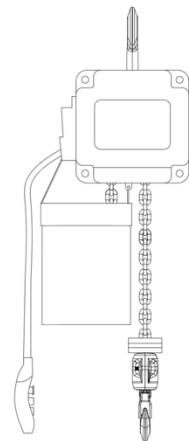
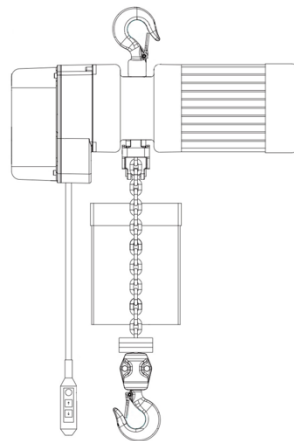
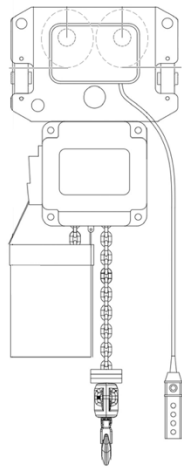
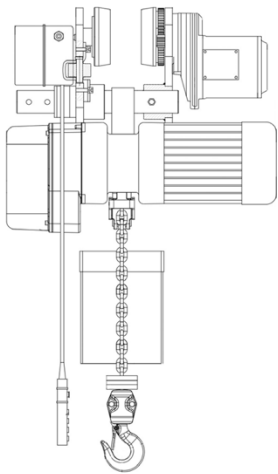

TABLE OF CONTENTS



HOIST SPECIFICATIONS

- Single Speed Hoist Page 3
- Single Speed Hoist + Trolley Page 4
- Dual Speed Hoist Page 5
- Dual Speed Hoist + Trolley Page 6

HOIST INSTALLATION

- Pre-installation Page 7
- Voltage Adjustment Page 7
- Installation Instructions Page 9

TROLLEY INSTALLATION

- Pre-installation Page 10
- Voltage Adjustment Page 11
- Installation Instructions Page 12
- Direction Adjustment..... Page 13

OPERATION

- Controls Page 16
- Advisory..... Page 16

MAINTENANCE

- Inspection Periods..... Page 17
- Hoist Brake Page 18
- Load Chain Page 19
- Trolley Brake Page 20
- Contactor Inspection Page 20
- Hook Inspection Page 21

DIAGRAMS

- Hoist Housing Assembly..... Page 23
- Hoist Gear Assembly..... Page 25
- Hoist Chain Reeving & Attachments..... Page 27
- Hoist Chain Entry & Limit Switch Assembly Page 29
- Motorized Trolley Assembly Page 31

ELECTRICAL DIAGRAMS

- 1 Ton - 5 Ton Single Speed Hoist Wiring..... Page 35
- 1 Ton Dual Speed Hoist Wiring..... Page 36
- 2 Ton – 5 Ton Dual Speed Hoist Wiring Page 37
- 1 Ton – 5 Ton Single Speed Hoist + Trolley Wiring Page 38
- 1 Ton – 5 Ton Dual Speed Hoist + Trolley Wiring Page 39

TECHNICAL SPECIFICATIONS

SINGLE SPEED HOIST

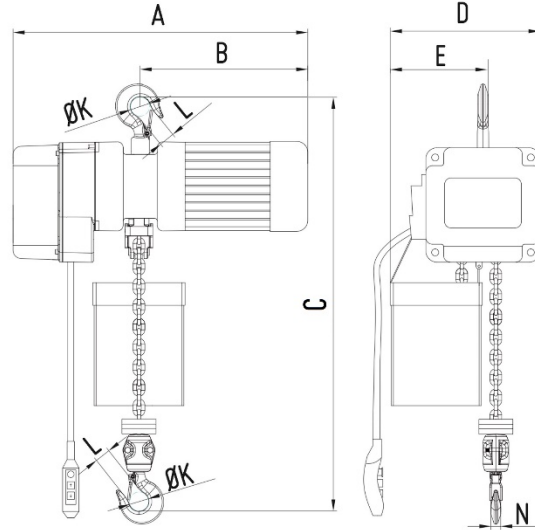

Product Code	Capacity	Headroom (C)	A	B	D	E	K	L	N
	<i>tons</i>	<i>inches</i>	<i>inches</i>	<i>inches</i>	<i>inches</i>	<i>inches</i>	<i>inches</i>	<i>inches</i>	<i>inches</i>
HHBD01SK-01	1	19.69	23.43	12.60	10.75	7.25	1.57	1.22	0.94
HHBD02SK-01	2	23.62	25.39	12.99	14.00	9.50	1.93	1.37	1.18
HHBD03SK-01	3	29.53	30.91	15.55	17.00	11.50	2.32	1.65	1.38
HHBD05SK-02	5	38.58	30.91	15.55	17.00	11.50	2.36	1.65	1.69

Product Code	Capacity	Standard Lift Height	Push Button Cord	Lifting Speed	Motor Output	Control Voltage	Lifting Motor Rated Current (amps)		Load Chain Size Ø	Chain Fall Lines	Net Weight
	<i>tons</i>	<i>feet</i>	<i>feet</i>	<i>ft/min</i>	<i>hp</i>	<i>Volts</i>	@230v	@460v	<i>mm</i>		<i>Lbs.</i>
HHBD01SK-01	1	20	17	23.6	2.01	110	6	4.5	Ø 8 x 24	1	125.7
HHBD02SK-01	2	20	17	14.4	2.01	110	6	4.5	Ø 10 x 30	1	188
HHBD03SK-01	3	20	17	17.7	4.02	110	11	8	Ø 11.2 x 34	1	298
HHBD05SK-02	5	20	17	9.2	4.02	110	11	8	Ø 11.2 x 34	2	364

TECHNICAL SPECIFICATIONS

SINGLE SPEED HOIST + TROLLEY

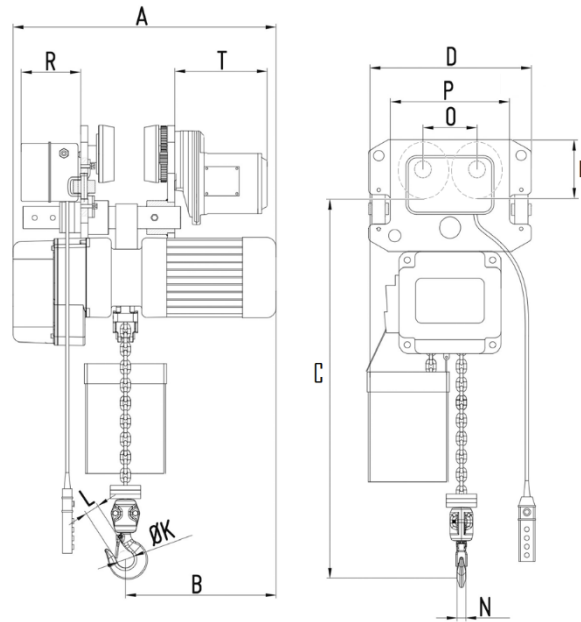

Product Code	Capacity	Headroom (C)	A	B	D	K	L	E	N	O	P	R	T
	<i>tons</i>	<i>inches</i>	<i>inches</i>	<i>inches</i>	<i>inches</i>	<i>inches</i>	<i>inches</i>	<i>inches</i>	<i>inches</i>	<i>inches</i>	<i>inches</i>	<i>inches</i>	<i>inches</i>
HHBD01SK-01 +WPC01	1	18.1	23.43	12.6	12.25	1.65	1.22	4.87	0.94	4.37	8.11	5.59	9.09
HHBD02SK-01 +WPC02	2	22	25.39	12.99	12.75	1.93	1.37	4.75	1.18	5.00	9.33	5.59	9.09
HHBD03SK-01 +WPC03	3	28	30.91	15.55	13.5	2.32	1.65	5.5	1.38	5.51	10.43	5.59	9.09
HHBD05SK-02 +WPC05	5	37	30.91	15.55	15.5	2.36	1.65	5.5	1.69	6.14	11.65	5.59	9.09

Product Code	Capacity	Standard Lift Height	Push Button Cord	Lifting Speed	Motor Output	Motor Rated Current (amps)		Load Chain Size Ø	Chain Fall Lines	Trolley Speed	Trolley Output	Trolley Flange Width	Net Weight
	<i>tons</i>	<i>feet</i>	<i>feet</i>	<i>ft/min</i>	<i>hp</i>	@230v	@460v	<i>mm</i>		<i>ft/min</i>	<i>hp</i>	<i>inches</i>	<i>lbs.</i>
HHBD01SK-01 +WPC01	1	20	17	23.6	2	6	4.5	Ø 8 x 24	1	48	0.5	3.15-12.00	213.8
HHBD02SK-01 +WPC02	2	20	17	14.4	2	6	4.5	Ø 10 x 30	1	48	0.5	3.23-12.00	277.8
HHBD03SK-01 +WPC03	3	20	17	17.7	4	11	8	Ø 11.2 x 34	1	48	0.5	3.94-12.00	434.3
HHBD05SK-02 +WPC05	5	20	17	9.2	4	11	8	Ø 11.2 x 34	2	48	1	4.33-12.00	560

TECHNICAL SPECIFICATIONS

DUAL SPEED HOIST

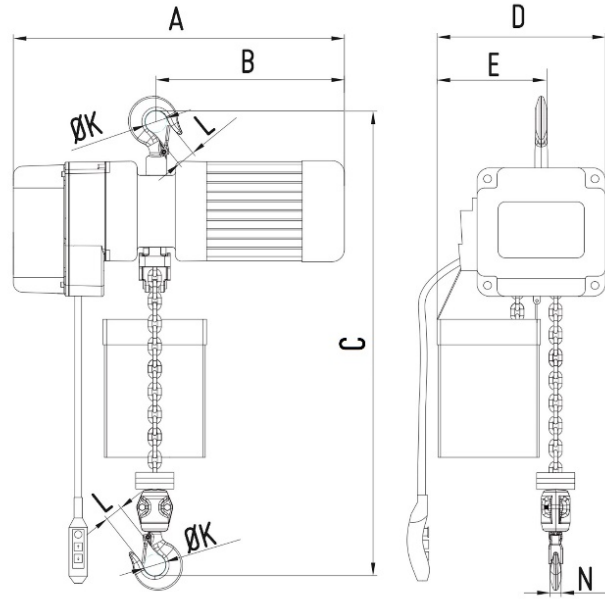

Product Code	Capacity	Headroom (C)	A	B	D	E	K	L	N
	<i>tons</i>	<i>inches</i>	<i>inches</i>	<i>inches</i>	<i>inches</i>	<i>inches</i>	<i>inches</i>	<i>inches</i>	<i>inches</i>
HHBDSK01-01D	1	20.15	23.54	12.6	11.81	8.31	1.57	1.26	0.94
HHBDSK02-01D	2	22.50	25.51	12.99	12.60	8.10	1.93	1.57	1.18
HHBDSK03-01D	3	30.95	31.02	15.55	18.31	12.75	2.32	1.77	1.38
HHBDSK05-02D	5	40.50	31.02	15.55	18.31	12.75	2.36	1.77	1.69

Product Code	Capacity	Standard Lift Height	Push Button Cord	Lifting Speed	Motor Output	Control Voltage	Lifting Motor Rated Current (amps)		Load Chain Size Ø	Chain Fall Lines	Net Weight
	<i>tons</i>	<i>feet</i>	<i>feet</i>	<i>ft/min</i>	<i>hp</i>	<i>Volts</i>	@230v	@460v	<i>mm</i>		<i>lbs.</i>
HHBDSK01-01D	1	20	17	23.6 / 7.9	2.01	110	9/3.8	7/2.4	Ø 8 x 24	1	147.70
HHBDSK02-01D	2	20	17	14.4 / 4.6	2.01	110	7/4	4.5/2.6	Ø 10 x 30	1	196.20
HHBDSK03-01D	3	20	17	24 / 4.8	4.02	110	8.5/12	6.5/8.5	Ø 11.2 x 34	1	330.70
HHBDSK05-02D	5	20	17	7.2 / 2.3	4.02	110	8.5/12	6.5/8.5	Ø 11.2 x 34	2	412.30

TECHNICAL SPECIFICATIONS

DUAL SPEED HOIST + TROLLEY

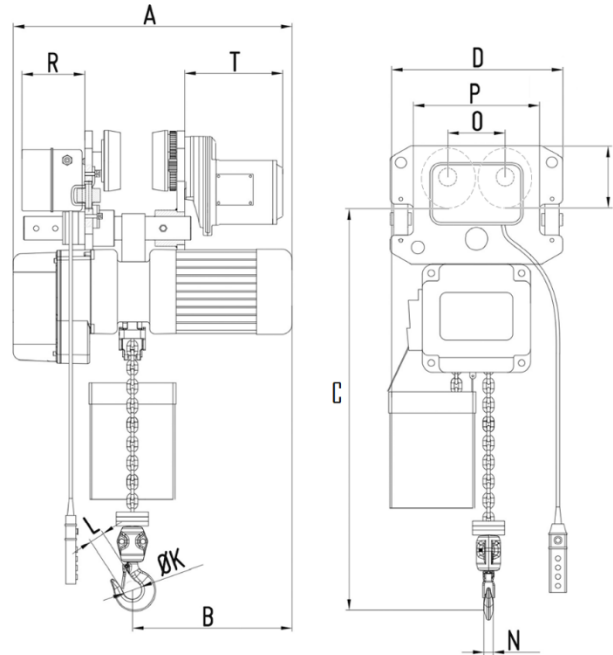

Product Code	Capacity	Standard Lift Height	Push Button Cord	Lifting Speed	Motor Output	Control Voltage	Lifting Motor Rated Current (amps)		Load Chain Size Ø	Chain Fall Lines	Trolley Speed	Trolley Output	Trolley Flange Width	Net Weight
	<i>tons</i>	<i>feet</i>	<i>feet</i>	<i>ft/min</i>	<i>hp</i>	<i>Volts</i>	@230v	@460v	<i>mm</i>		<i>ft/min</i>	<i>hp</i>	<i>inches</i>	
HHBDSK01-01D +WPC01D	1	20	17	23.6 / 7.9	2.01	110	9/3.8	7/2.4	Ø 8 x 24	1	90 / 32	0.5	3.15-12.00	257.9
HHBDSK02-01D +WPC02D	2	20	17	14.4 / 4.6	2.01	110	7/4	4.5/2.6	Ø 10 x 30	1	80 / 28	0.5	3.23-12.00	321.9
HHBDSK03-01D +WPC03D	3	20	17	24 / 4.8	4.02	110	8.5/12	6.5/8.5	Ø 11.2 x 34	1	64 / 24	0.5	3.94-12.00	478.4
HHBDSK05-02D +WPC05D	5	20	17	7.2 / 2.3	4.02	110	8.5/12	6.5/8.5	Ø 11.2 x 34	2	60 / 21	1	4.33-12.00	615.1

Product Code	Capacity	Headroom (C)	A	B	D	E	K	L	N	O	P	R	T
	<i>tons</i>	<i>inches</i>	<i>inches</i>	<i>inches</i>	<i>inches</i>	<i>inches</i>	<i>inches</i>	<i>inches</i>	<i>inches</i>	<i>inches</i>	<i>inches</i>	<i>inches</i>	<i>inches</i>
HHBDSK01-01D +WPC01D	1	18.11	23.54	12.6	12.25	4.75	1.65	1.26	0.94	4.37	8.11	5.59	9.09
HHBDSK02-01D +WPC02D	2	22.05	25.51	12.99	12.75	4.75	1.93	1.57	1.18	5	9.33	5.59	9.09
HHBDSK03-01D +WPC03D	3	27.95	31.02	15.55	13.5	5.5	2.32	1.77	1.38	5.51	10.43	5.59	9.09
HHBDSK05-02D +WPC05D	5	37.01	31.02	15.55	15.5	5.5	2.36	1.77	1.69	6.14	11.65	5.59	9.09

HOIST INSTALLATION



PRE-INSTALLATION INSPECTION

1. Remove your hoist from the crate.
2. Take note of the preset voltage that your hoist has been set to. This information can be found on the lid of the shipping crate. If you are not sure of your hoist voltage, contact Bison's customer service.
3. Give the hoist a visual inspection. Look for any obvious defects or damage to the unit.
4. Always make sure your power supply is disconnected before you wire your hoist.
5. If necessary, make the changes to your hoists voltage by following the steps below.

HOIST DUAL VOLTAGE ADJUSTMENT

All hoists come with the option of using either 460v or 230v power supply. The default voltage on all hoists is prewired for 460v. (unless otherwise stated)

This can be adjusted as follows:

1. **Transformer Connection:** The transformer like the hoist is wired as standard from the factory for an incoming power supply of 460v. The Red wire (0V) of the transformer is connected to **T2** of the reversing contactor. The Blue wire (460V) is connected to **T3** of the same reversing contactor.

If the incoming power supply is changed to 230v then the Yellow wire of the transformer (230V) should be connected to **T3** of the reversing contactor. The Blue wire (460V) must be disconnected from **T3** and well insulated. Ensure the cable is insulated in a manner that will not allow it to float around in the panel.

2. **Motor Connection:**

Single Speed: The Hoist motor is wired as standard from the factory for an incoming power supply of 460v. There are 6 wires from the motor Labelled **U1; V1; W1; W2; U2; V2**. The standard 460v connection is **W2/U2/V2** are joined together and **U1/V1/W1** are connected to **T1/T2/T3** of the reversing contactor. For 230v main incoming supply voltage then a parallel connection of the wires is required as follows: **W2&U1** connect to **T1-U2&V1** connect to **T2-V2&W1** connect to **T3**.

Dual Speed: For Dual speed 230V connection look for the 2 sets of 3 cables that come from the motor stator that have a cable nut or crimp connecting them together. They are normally tucked behind the contactor backing plate to the left of the hoist panel. 1 set will be red wires and the other set will be black wires. The red wires will be for slow and the black wires will be for fast.

Connect each set as you would a single speed motor as explained above, make sure you connect the red wires to the red wires on the bottom of the slow contactor terminals **T1-T2-T3** and the same with the black wires onto the fast contactor terminals **T1-T2-T3**

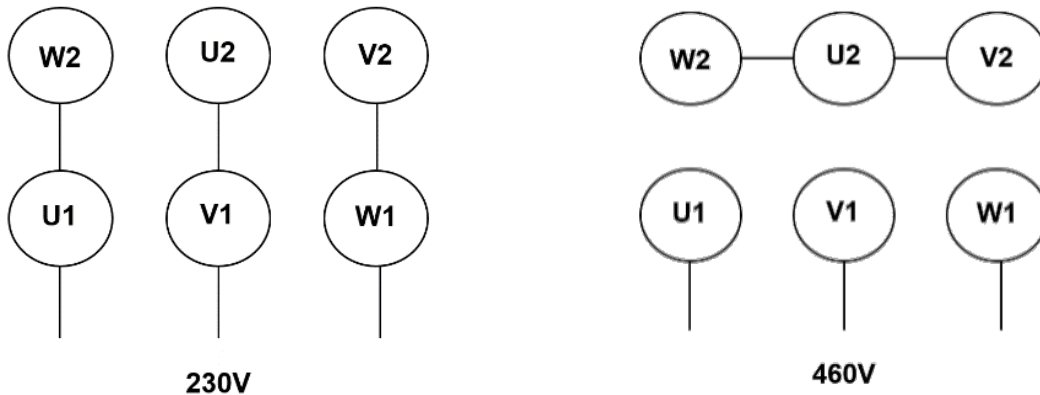
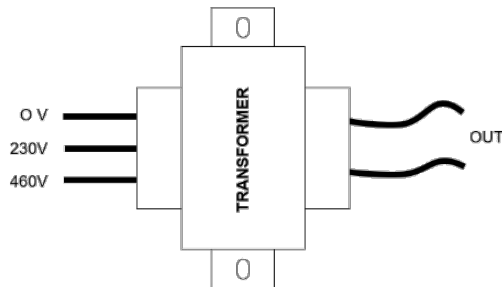

HOIST INSTALLATION

1. The hoist comes already filled with oil. No oil needs to be added inside the hoist during installation.
2. Be sure that the hoist is mounted to or from a structure that can support the hoist and its rated load.
3. Using the power cord, either connect the hoist to your plug or a junction box.
4. To start the hoist, release the red emergency stop button on the controller by twisting the red knob clockwise till it pops out and then press the start or on button (if applicable).
5. Once the emergency stop button has been released and the start/ on button has been pressed you should instantly hear a click in the hoist as the main contactor comes in. You can now test the hoist directions.
6. If you have wired your hoist to the power supply and the hoist is not functioning it may be because your phases are reversed. This can be checked by opening the front cover of the hoist. There you will find a small white relay with led lights on it. If the fault light is on you must swop any 2 of the 3 power cables at your plug or junction box.



FLASHING FAULT
 LIGHT = PHASES
 ARE REVERSED

7. Before proceeding to operate the hoist, check that the hoist directions are correct, that the emergency stop button works and that the limit switches work.
8. Apply the oil provided to the chain for easier operation and to prolong the lifespan.
9. To attach the chain bag/ container run the hoist until the hook is fully extended (DOWN) and then fasten the bag/ container to the hoist. Once the bag is securely fastened feed the slack chain (non-load bearing) into the bag/ container. Then run the hoist in the reverse motion (UP), guiding the slack chain into the bag/ container (only applicable for those models supplied with the bag/ container).

PRE-INSTALLATION INSPECTION



1. Remove your hoist and the trolley from the crate.
2. If necessary, make the changes to your hoist's voltage. (Refer to page 7.) remember any voltage changes that are made in the hoist must be made in the trolley's motor panel. (The transformer in the hoist operates the hoist & the trolley)

Trolley Dual Voltage Adjustment:

When opening the trolley's crate, you will find that the trolley motor is not connected yet to the panel that houses the trolley contactors. This is done for transportation and site fitment purposes allowing the trolley to be separated completely during installation without the cable hindering the installation onto the beam.

460v = Star Connection

230v = Delta Connection

Single Speed

On a single speed 460v Trolley you will have a short black cable from the trolley enclosure with 3 wires marked U1/V1/W1, these will go into the gland on the trolley motor and be connected to the corresponding U2/V2/W2 on the motor terminal strip.

If the main incoming voltage is 230v then the trolley needs to be reconfigured to a delta connection as per the below chart.

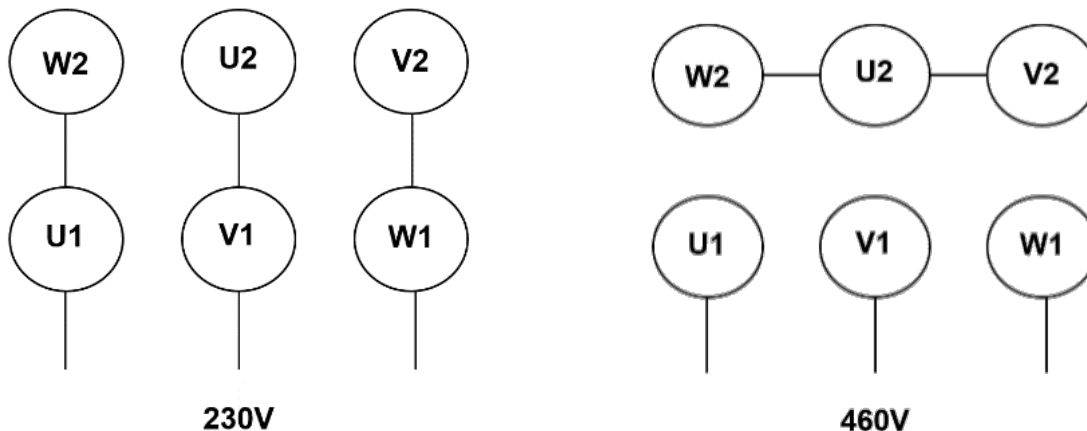

HOIST + MOTORIZED TROLLEY ASSEMBLY & INSTALLATION

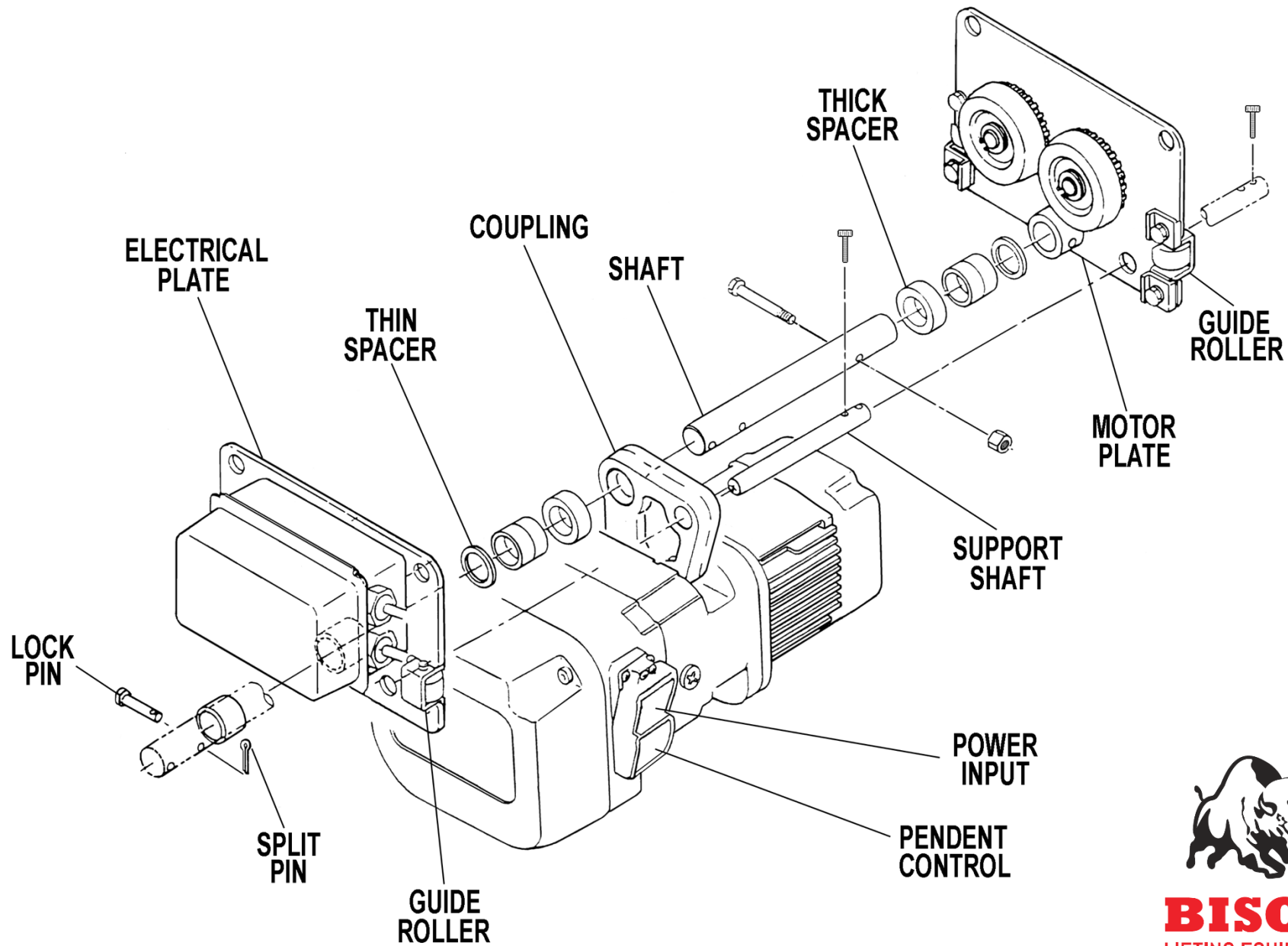

BISON
LIFTING EQUIPMENT

TROLLEY INSTALLATION

1. Be sure that your beam and its structure can support the weight of the hoist and its rated load.
2. The trolley comes packaged already assembled. To attach the hoist, you will need to remove the lock pin from the end of the shaft and any external spacers. Remove the electrical plate and any spacers.
3. To fit the trolley to the beam you will need to calculate the correct number of spacers on both sides of the coupling so that the center of the coupling is in line with the web of the beam. Take the measurement of your beam flange.
4. You will need to lay out the trolley to measure the number of spacers you will need. Connect the 2 trolley plates together by inserting the shaft into the plates. Take note of the guide rollers on each plate. These guide rollers are where the internal measurement will be taken. Spread the plates the same distance apart as the width of the beam's flange. Now you can measure how many spacers you will need on the shaft- either side of the coupling. Make sure to leave 1/8-inch space on both sides of the coupling. (Refer to the diagrams below)

(Flange width – thickness of coupling + ¼ inch = total length of spacers)

All 4 guide rollers must roll along the edge of the beam flange. The ¼-inch space that was left is to allow the trolley to roll without getting caught while moving.

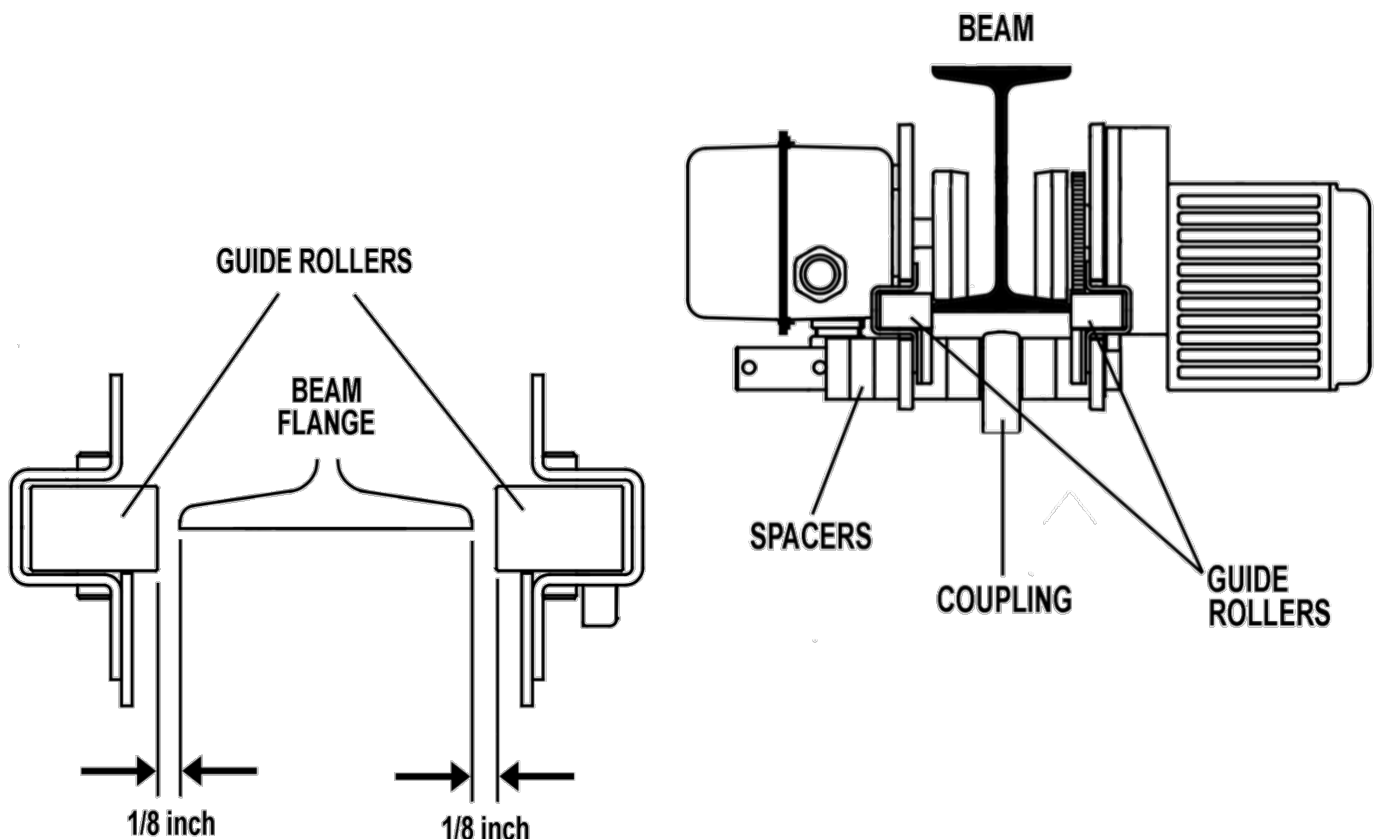



5. Once you have worked out the number of spacers you will need, any left-over spacers must be packed on the exposed outside end of shaft. Once you are ready to mount the trolley.
6. To mount the trolley to the beam you must couple the motor end of the trolley with your correct number of spacers onto the hoist, followed by the rest of the spacers and the electrical plate.
7. The trolley which is now mounted to the hoist must be kept spread wide enough to fit the wheels inside the beam.
8. Once the wheels are inside the beam you can push the trolley together.
9. Fit the left-over spacers on the outside of the exposed beam tight enough for the lock pin to hold the spacers in place.
10. Make sure to secure the Lock pin with the split pin.
11. After the trolley has been mounted to the beam, the trolley motor must be connected. There is a short cable from the electrical panel of the trolley which provides power to the trolley motor.

**TROLLEY MOTOR
WIRED FOR 460V**

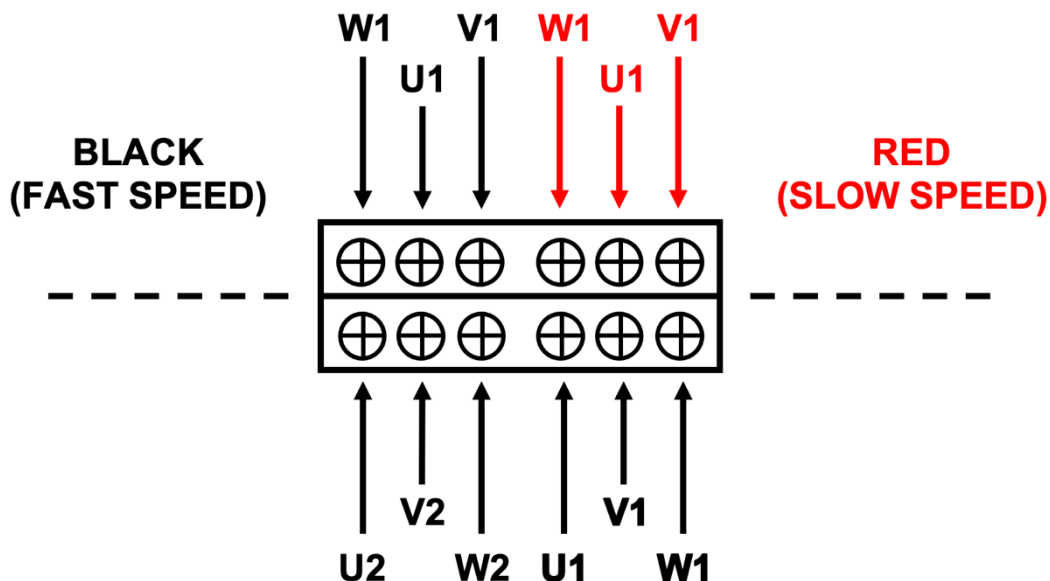

**TROLLEY MOTOR CORD
(U1, V1, W1) & (U2, V2, W2)**



12. Plug in and fasten the trolley plugs into the hoist.
13. The hoist is now ready to test. Connect the power cord to the mains.
14. Once the emergency stop has been released and the start/ on button has been pressed you should instantly hear a click in the hoist as the main contactor comes in. You can now test the hoist and trolley directions. Before proceeding to operate the hoist, check that the hoist directions are correct, that the emergency stop button works and that the limit switches work.
15. If you have wired your hoist to the power supply and are not getting any power to the hoist you might have reversed 2 of the phases. This can be checked by opening the front cover of the hoist. There you will find a small white relay with led lights on it. If the fault light is on you must swop any 2 of the 3 power cables. (Refer to page X)
16. If your trolley's directions are not correct, wiring changes in the trolley will need to be made.

TROLLEY DIRECTION CHANGE

If after having wired the trolley in and you find that directions are wrong this can easily be rectified by following these steps.

Single speed: If when you push the cross travel direction the hoist/trolley moves in a particular direction and you want it to move in the opposite direction when you push the same button open up the trolley motor and swop positions of 2 of the wires of the cable you previously installed such as u1 with v1, this is known as phase reversal, now when you push the cross travel directional button the trolley will move in the opposite direction.

Dual Speed: After completing the wiring and when testing for the first time be very careful when operating the trolley. Conduct a small momentary test by pushing the slow button in any direction and testing if slow is the first speed, if the trolley moves quickly you may have wired it incorrectly, go back and check wiring in the motor.

DUAL SPEED DIRECTION CHANGE



Once wiring is correct and when you push slow the hoist moves in each direction slowly then momentarily test the fast, if the hoist continues moving in the same direction in fast as it did in slow then you have completed the trolley wiring successfully, however if the fast speed suddenly changes the direction that the hoist was travelling when in slow you need to go the trolley terminal strip and swop 2 phases on (**U2**) Locate the electrical panel of the trolley motor.

1. Remove the cover.
2. Inside you will find 3 black cables, crimped together and 3 red cables crimped together. These must be left crimped together if the host and trolley are running on 460v.
3. There are 6 cables already connected to the terminal strip from trolley's motor. A set of 3 red cables and a set of 3 black cables.
4. Feed the short cable coming from the trolley's contactor control box into the motor panel following the diagram above.
5. You can now power up the trolley and test the directions.

NOTE:

Depending on the factory's order of the trolley motor wiring, you might find your fast and slow speed's directions are swoped. This can be simply corrected by changing 2 cables. Example: take V1 and W1 and swop them around.

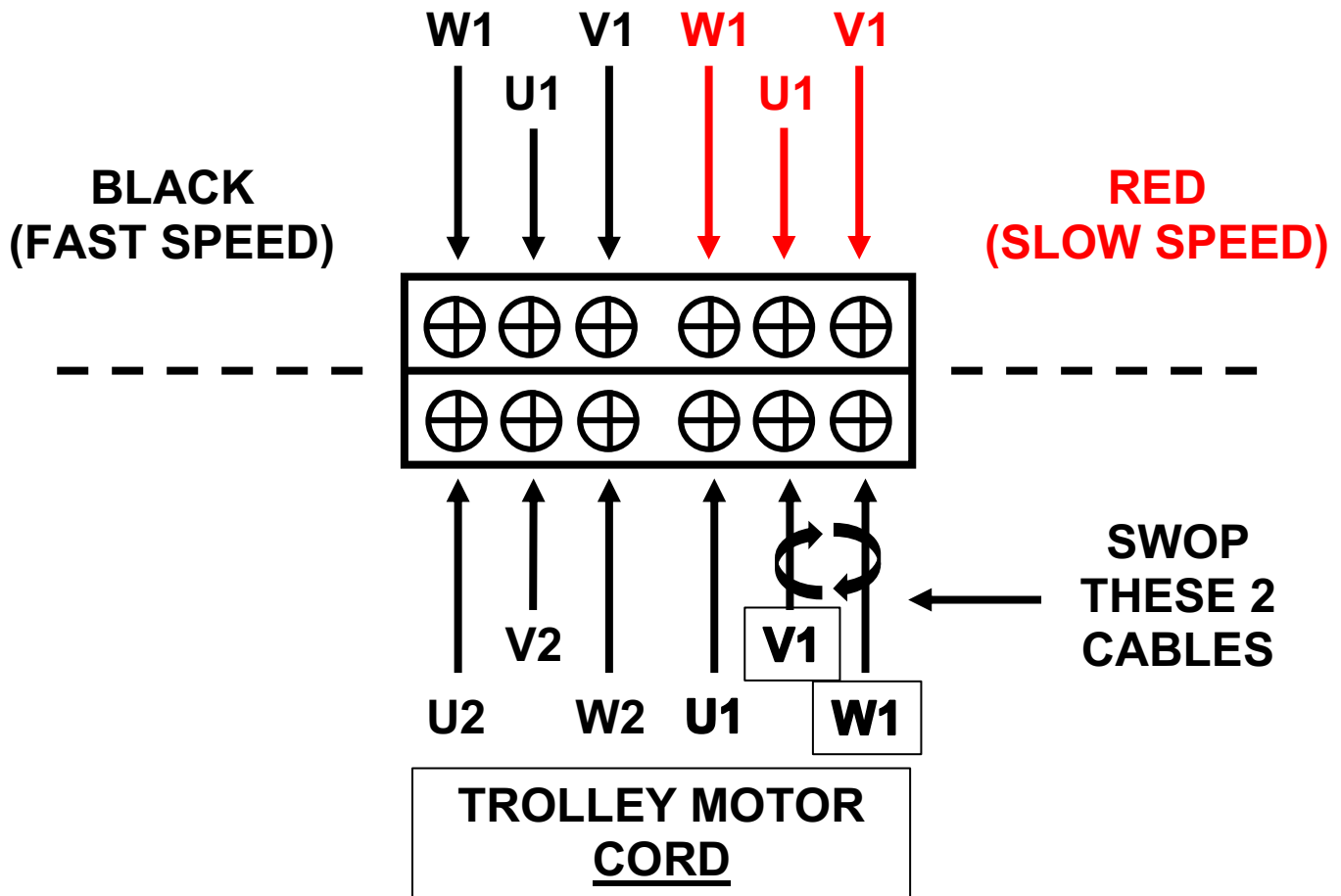

OPERATION



Hoisting:

Dual speed models are controlled by pushing the pendent buttons down in 2 stages of depression. Single depression engages a slow speed. Full depression engages the fast speed.

Install the hoist to a support structure. It is the user/ owner's responsibility to ensure the chosen support structure has the sufficient strength to support the hoist and the rated working load.

Do not attempt to lengthen the load chain in any way. Do not attempt to repair the hooks.

General:

1. The friction-clutch is designed to allow the first reduction gear to slip on an excessive overload. An overload is indicated when the hoist will not raise the load. Also, some clutching noise may be heard if the hoist is loaded beyond rated capacity. Should this occur, immediately release the raising control to stop operation of the hoist. At this point, the load should be reduced to the rated hoist capacity. When the excessive load is removed, normal hoist operation is automatically restored. [CAUTION: the friction clutch is susceptible to overheating and wear when slipped for extended periods. Under no circumstance should the friction clutch be allowed to slip for more than a few seconds.]
2. Before picking up a load, check to see that the hoist is directly overhead. Avoid off-center loading of any kind.
3. Take up as lack load chain carefully and start hoisting load gently to avoid shock and jerking of the load chain. If there is any evidence of overloading, immediately lower the load and remove the excess load.
4. Do not allow the load to swing or twist while hoisting.
5. Do not allow the load to be against the hook latch or the tip of the hook.
6. Make sure the pendant cord is straight and is not tangled in the chain. Be careful not to snag the cord on any sharp edges or objects.
7. When handling material that is being immersed in water, baths or any liquid, use a chain sling to prevent the hook block from having to be submerged- this will stop any liquid from penetrating the bearing.

Precautions

- During overhead lifting operations, personnel should NOT stand beneath the suspended load.
- Prevent the load chain from dragging over sharp edges or corners.
- Be cautious of having fingers caught in the mechanisms.
- Do NOT attempt to lift people.
- Do NOT use the load chain to basket or choke a load.
- Do NOT drag or drop the hoist.

- Do NOT put the bottom hook through the loop of the chain. (only applicable on 2-fall models)



MAINTENANCE:

The inspection procedure advised is based on ANSI/ASME B30.16. The following definitions are from ANSI/ASME B30.16.

INSPECTION CLASSIFICATION

The inspection procedure is divided into two general grades based upon the intervals at which inspection should be performed.

HOIST SERVICE DUTY	
DUTY	Average % of rated capacity
NORMAL	0 to 33%
HEAVY	33 to 67%
SEVERE	67% TO 100%
SPECIAL	SPECIAL CONDITIONS

Frequent: Operators are to make visual inspections as often as required.

- Normal Duty Service – monthly
- Heavy Duty Service – weekly to monthly
- Severe Duty Service – daily to weekly
- Special Duty Service – recommend being inspected by a qualified individual before and after each operation.

Periodic: Qualified individuals are to make visual inspections as often as required.

- Normal Duty Service – annually
- Heavy Duty Service – semiannually (twice a year)
- Severe Duty Service – quarterly
- Special Duty Service – recommend being inspected by a qualified individual before and after each operation.

FREQUENT INSPECTION

The following is required to be inspected frequently:

- All functional operating mechanisms.
- Functionality of limit switch
- Hoist braking system
- Hooks in accordance with ANSI/ASME B30.10
- Hook latches
- Load chain
- Load chain reeving



Periodic Inspection

The following is required to be inspected periodically:

ANSI/ASME B30.16 requires all hoists subject to disassembly of load suspension parts, to undergo a load test after re-assembly to pass full inspection.

Requirements of frequent inspection:

- Evidence of loose bolts, nuts, or rivets.
- Evidence of wear, corrosion, cracks, or distortion to parts such as load blocks, suspension housing, chain attachments, clevises, coupling, suspension bolts, shafts, gears, bearings, pins and rollers.
- Evidence of damage to bottom block assembly.
- Evidence of excessive wear on motor or load brake.
- Evidence of damage of supporting structure/ trolley.
- Direction labels on pendant control stations.
- Warning labels properly attached to the hoist.
- Load chain end connections.
- Evidence of wear, cracks or stretching on the load chain.

LOAD BRAKE ADJUSTMENT

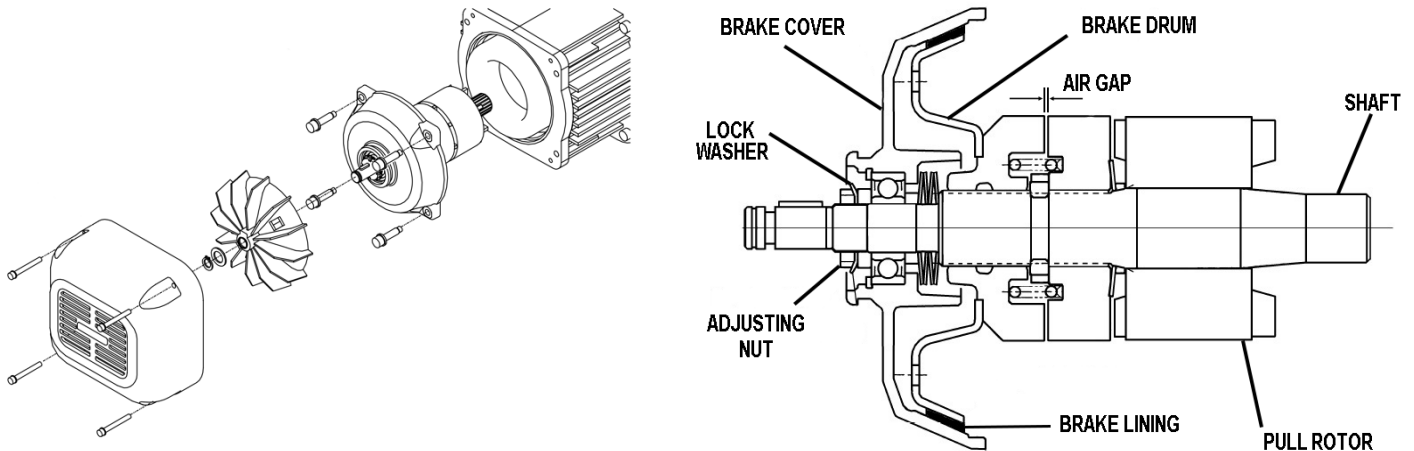

Brake device should be checked and cleaned of all dust and oil every three months.

The air gap of the brake is as standard 0.078 inches. The gap should be measured between the brake drum and pull rotor. The gap adjustment is done by turning the adjustment nut (refer to diagram above). Using a feeler gauge, measure the gap. Adjust until set. If the gap will not set, disassemble the motor brake and inspect all motor brake parts and the order. If necessary, replace the brake drum or motor cover.

If the electric chain hoist is mounted to an electric trolley, it is important to inspect both brakes- Trolley and Hoist.

BRAKE DRUM LINING (SINGLE SPEED)		
HOIST CAPACITIES	DEFAULT	REPLACE
	INCHES	INCHES
1 TON	0.31	0.23
2 TON	0.31	0.23
3 TON	0.31	0.23
5 TON	0.31	0.23

BRAKE DRUM LINING (DUAL SPEED)		
HOIST CAPACITIES	DEFAULT	REPLACE
	INCHES	INCHES
1 TON	0.28	0.20
2 TON	0.28	0.20
3 TON	0.28	0.20
5 TON	0.28	0.20

CHAIN INSPECTION

Inspect the chain for excessive, stretch, wear, corrosion or cracks. If the load chain shows any of these signs, the chain must be replaced immediately.

It is most vital that (P) and (D) be measured and inspected on the chain links.

1. Measure the pitch (P) for evidence of stretching. Using the table below as reference, ensure that the measurement is within 5% tolerance of the original value. If the measurement reading is greater than the 5% tolerance, the chain must be discarded.

2. Measure the diameter (D) for evidence of wear or corrosion. Using the table below as reference, ensure the diameter is within 10% tolerance of the original value. If the measurement reading is less than the 10% tolerance, the chain must be discarded.

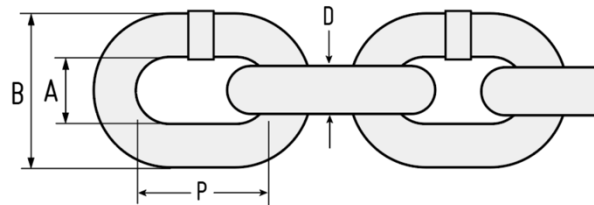

LOAD CHAIN WEAR				
HOIST CAPACITIES:	D	A	B	P
1 TON	8mm	10.3mm	26.3mm	24.0mm
2 TON	10mm	12.5mm	33.2mm	30.0mm
3 TON	11.2mm	14.0mm	37.2mm	34.0mm
5 TON	11.2mm	14.0mm	37.2mm	34.0mm

GEAR BOX OIL INSPECTION

The hoist features a friction clutch. Ensure the oil reservoir is always kept at a sufficient level of volume. Keep the hoist in the natural horizontal suspended position. Locate the oil plug on the top surface of the gear case, use a *Meropa 320* oil to fill the reservoir till sufficiently filled, refer to the chart below. [to drain the hoist during service or transportation, remove the plug on the bottom of the gear case]

GEAR OIL VOLUME	
HOIST CAPACITIES:	QUARTS
1 TON	1.06
2 TON	1.8
3 & 5 TON	3.17

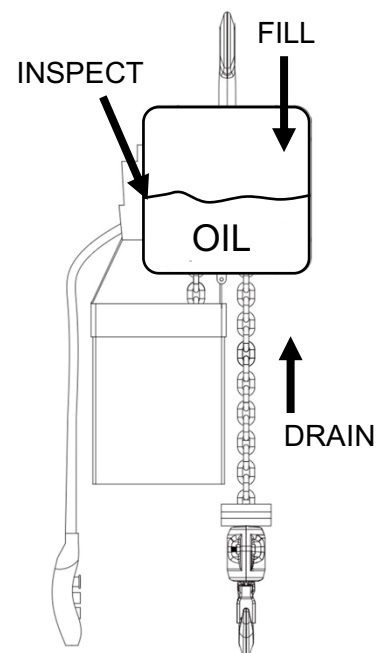

TROLLEY BRAKE INSPECTION

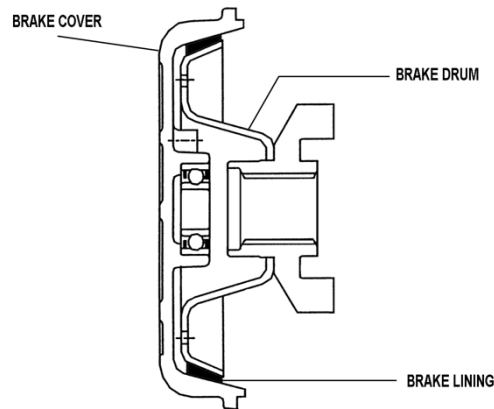

Inspect the trolley's brake lining for wear.

If the trolley's brake lining measures the "Replacement" value or a higher dimension, discard and replace the trolley's brake assembly.

Single Speed:

- The trolley brake lining as standard is 0.31 inches
- If the trolley brake lining is less than 0.23 inches, it should be replaced.

Dual Speed:

- The trolley brake lining as standard is 0.28 inches
- If the trolley brake lining is less than 0.20 inches, it should be replaced.

The trolley brake is non-adjustable.

CONTACTOR INSPECTION

Refer to the chart below for the recommended work rating of the hoist's contactors.
 (Jogging: when the pendant control buttons are pressed quickly and repetitively in to move the hook in small increments)

RECOMMENDED CONTACTOR REPLACEMENT	
FREQUENCY OF JOGGING	REPLACEMENT CONTACTOR AFTER: (START)
JOGGING IS RARE	1,000,000
DURING 25% OF OPERATIONS	500,000
DURING 50%+ OF OPERATIONS	200,000

HOOK INSPECTION

Inspect the hook for damage such as cracks, bends and excessive wear. While inspecting the hook, measure points K, T and U. Refer to the table below to judge whether the measurement is within the tolerance or not. If the measurement reaches the value in column “Replace” or greater, the hook needs to be replaced immediately.

Ensure the hook has a safety latch and that it is not bent or damaged that could result in an application to slip off or out the hook.

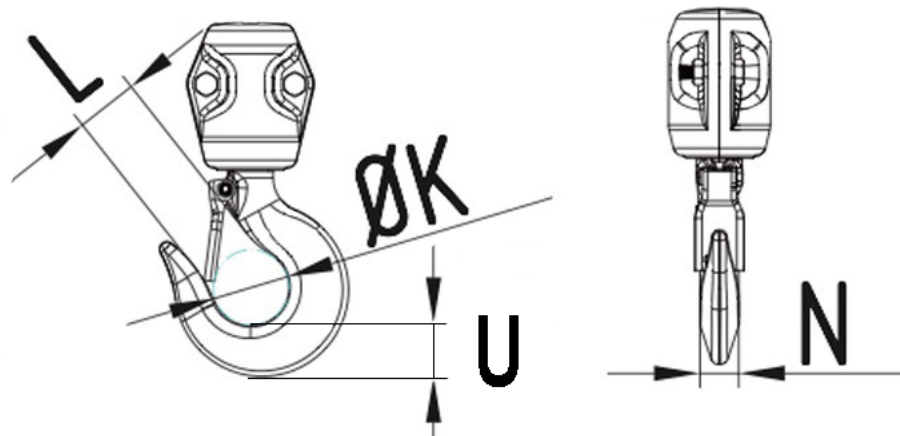

CAPACITY:	SIZE: N (INCHES)		SIZE: U (INCHES)		SIZE: K (INCHES)	
	STANDARD	REPLACE	STANDARD	REPLACE	STANDARD	REPLACE
1	0.94	0.79	1.18	1.1	1.26	1.13
2	1.18	1.02	1.54	1.42	1.57	1.41
3	1.34	1.22	1.93	1.69	1.77	1.59
5	1.73	1.5	2.24	1.97	1.77	1.59

HOIST HOUSING ASSEMBLY

Diagram A.



BISON
LIFTING EQUIPMENT

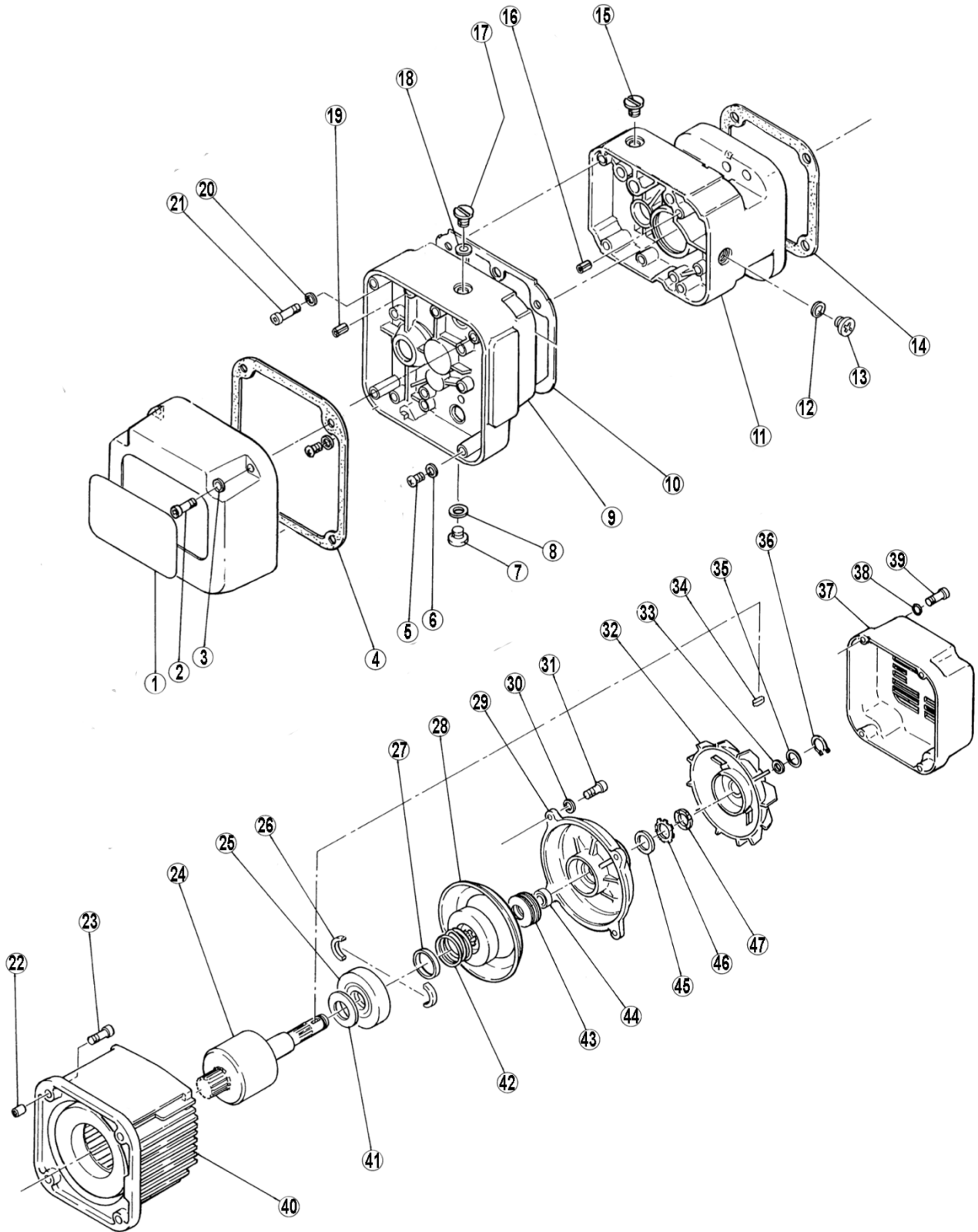

HOIST HOUSING ASSEMBLY

Diagram A.



PARTS LIST			
PART NO.	PART NAME	PART NO.	PART NAME
1.	HOIST NAME PLATE	25.	PULL ROTOR
2.	SOCKET SCREW	26.	THRUST DISC
3.	FLAT WASHER	27.	THRUST COLLAR
4.	HOIST ELECTRICAL GASKET	28.	BRAKE DRUM ASSEMBLY
5.	COVER HINGE RETAINING SCREW	29.	MOTOR COVER ASSEMBLY
6.	SPLIT WASHER	30.	SPLIT WASHER
7.	OIL DRAIN PLUG	31.	SOCKET SCREW
8.	RUBBER SEAL	32.	FAN
9.	GEAR BOX CASTING PT. 1	33.	SEAL
10.	GEAR BOX GASKET	34.	KEY
11.	GEAR BOX CASTING PT. 2	35.	FAN WASHER
12.	RUBBER SEAL	36.	SNAP RING
13.	OIL INSPECTION PLUG	37.	FAN COVER
14.	MOTOR GASKET	38.	SPLIT WASHER
15.	OIL FILL PLUG (A.)	39.	SOCKET SCREW
16.	SLOTTED PIN	40.	MOTOR FRAME WITH STATOR
17.	OIL FILL PLUG (B.)	41.	CONED DISC SPRING
18.	RUBBER SEAL	42.	BRAKE SPRING
19.	SLOTTED PIN	43.	CONED DISC SPRING
20.	SPLIT WASHER	44.	COLLAR
21.	SOCKET SCREW	45.	SPACER
22.	SLOTTED PIN	46.	LOCK WASHER
23.	SOCKET SCREW	47.	NUT
24.	MOTOR SHAFT WITH ROTOR		

HOIST GEAR ASSEMBLY

Diagram B.

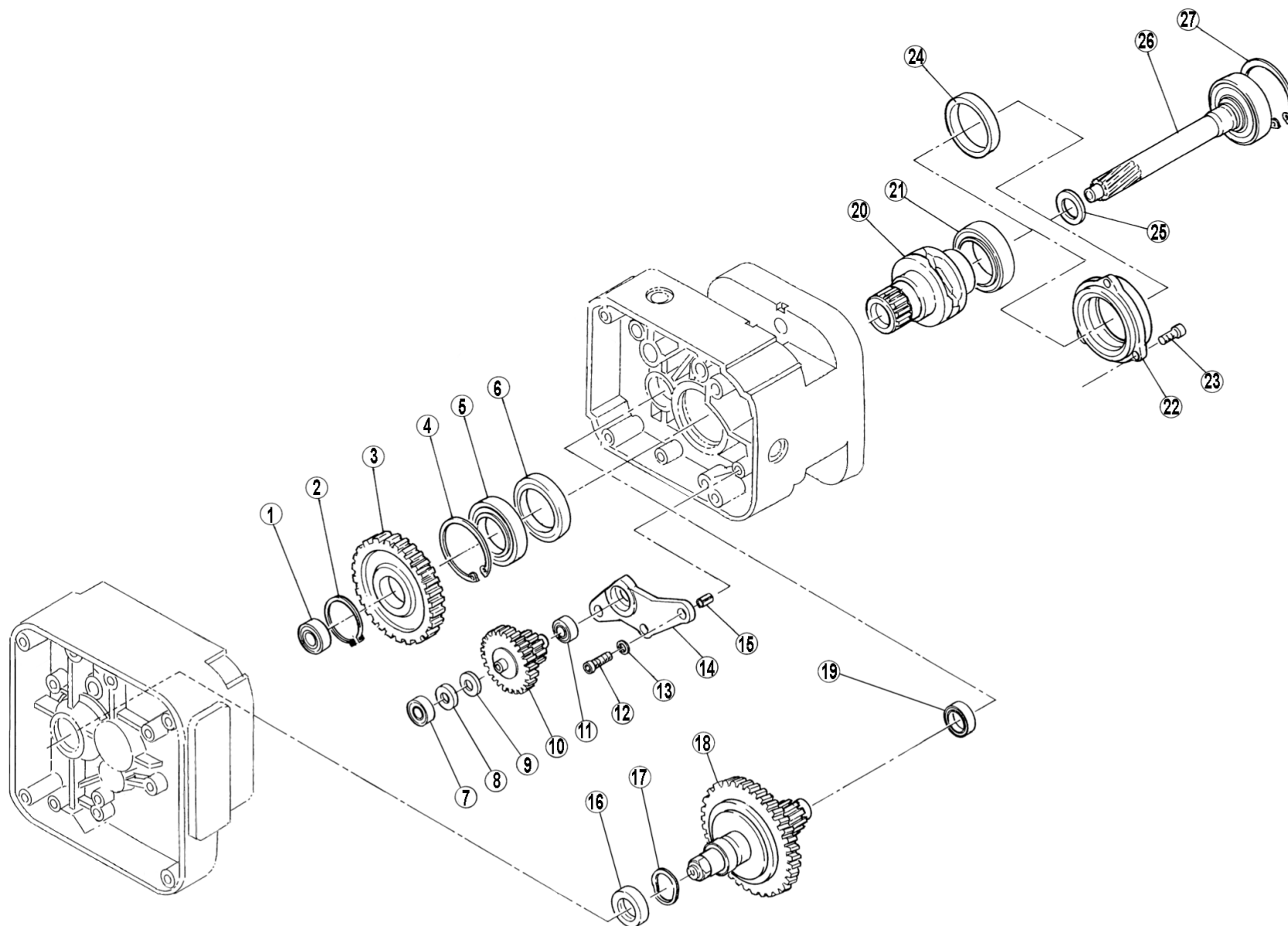

HOIST GEAR ASSEMBLY

Diagram B.



PARTS LIST			
PART NO.	PART NAME	PART NO.	PART NAME
1.	BALL BEARING	25.	OIL SEAL
2.	SNAP RING	26.	PINION ASSEMBLY
3.	LOAD GEAR	27.	SNAP RING
4.	SNAP RING		
5.	BALL BEARING		
6.	OIL SEAL		
7.	BALL BEARING		
8.	THRUST NEEDLE BEARING		
9.	THRUST PLATE		
10.	GEAR ASSEMBLY		
11.	BEARING		
12.	SOCKET SCREW		
13.	SPRING WASHER		
14.	GEAR PLATE		
15.	SLOTTED PIN		
16.	OIL SEAL		
17.	CURVED WASHER		
18.	FRICTION CLUTCH ASSEMBLY		
19.	BALL BEARING		
20.	CHAIN POCKET WHEEL		
21.	BALL BEARING		
22.	BEARING HOLDER		
23.	SOCKET SCREW		
24.	COLLAR		

HOIST CHAIN REEVING & ATTACHMENTS

Diagram C.



BISON
LIFTING EQUIPMENT

TROLLEY COUPLING

5 TON
TOP HOOK
COUPLING
(2 CHAIN FALL)

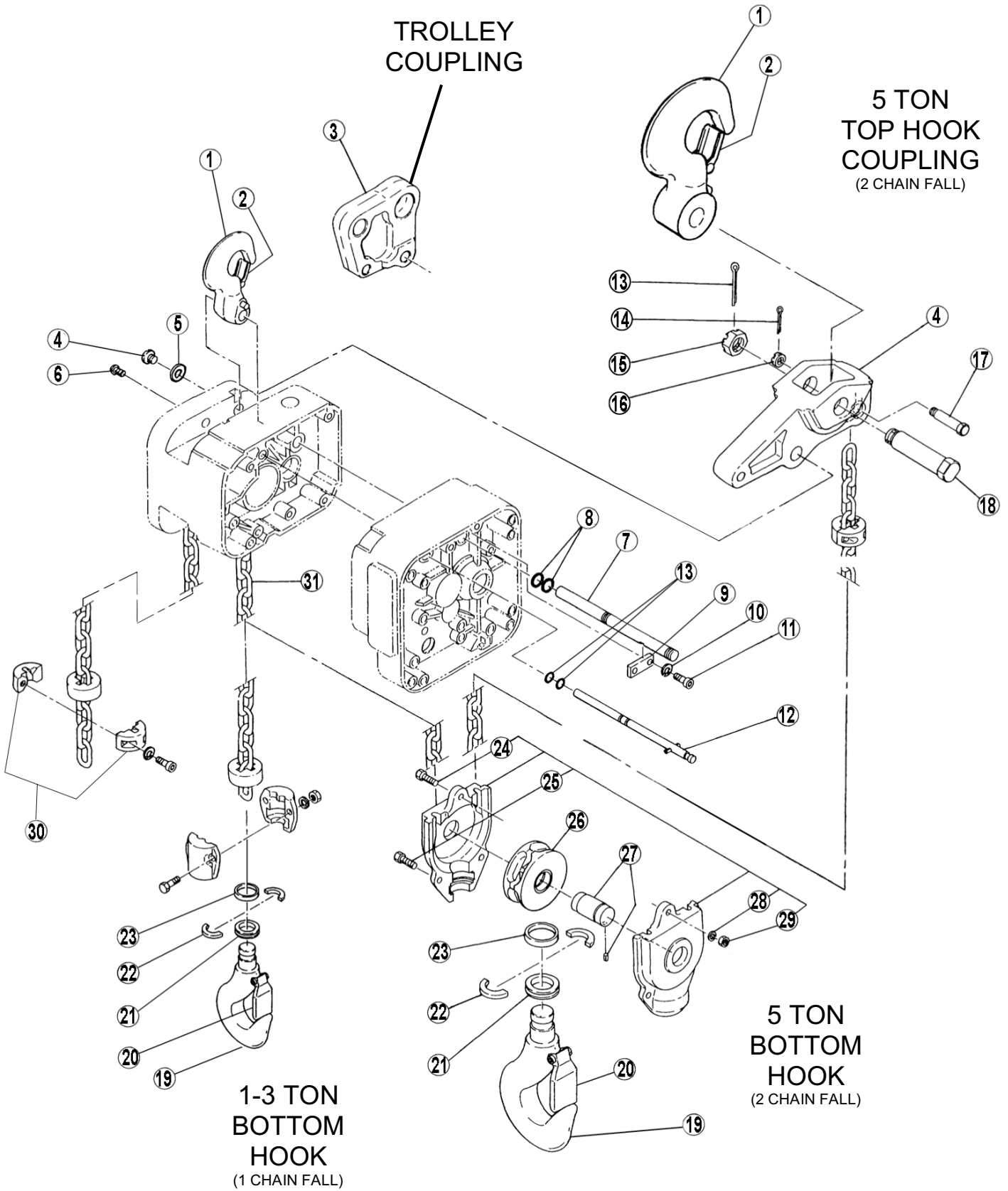

1-3 TON
BOTTOM
HOOK
(1 CHAIN FALL)

5 TON
BOTTOM
HOOK
(2 CHAIN FALL)

HOIST CHAIN REEVING & ATTACHMENTS

Diagram C.



PARTS LIST			
PART NO.	PART NAME	PART NO.	PART NAME
1.	TOP HOOK	24.	BOLT
2.	SAFETY LATCH	25.	BOLT
3.	TROLLEY MOUNT COUPLING	26.	BOTTOM BLOCK POCKET WHEEL
4.	SHAFT PLUG	27.	BOTTOM BLOCK SHAFT
5.	OIL SEAL	28.	SPLIT WASHER
6.	SCREW	29.	NUT
7.	LOAD BEARING SHAFT	30.	CHAIN COLLAR ASSEMBLY
8.	O RING		
9.	SHAFT KEY PLATE		
10.	SPLIT WASHER		
11.	SCREW		
12.	SUPPORT SHAFT		
13.	SPLIT PIN		
14.	SPLIT PIN		
15.	CASTLE NUT		
16.	CASTLE NUT		
17.	CHAIN PIN		
18.	TOP HOOK BOLT		
19.	BOTTOM BLOCK		
20.	SAFETY LATCH		
21.	THRUST BEARING		
22.	HOOK STOPPER		
23.	THRUST COLLAR		

HOIST CHAIN ENTRY & LIMIT SWITCH ASSEMBLY

Diagram D.



BISON
LIFTING EQUIPMENT

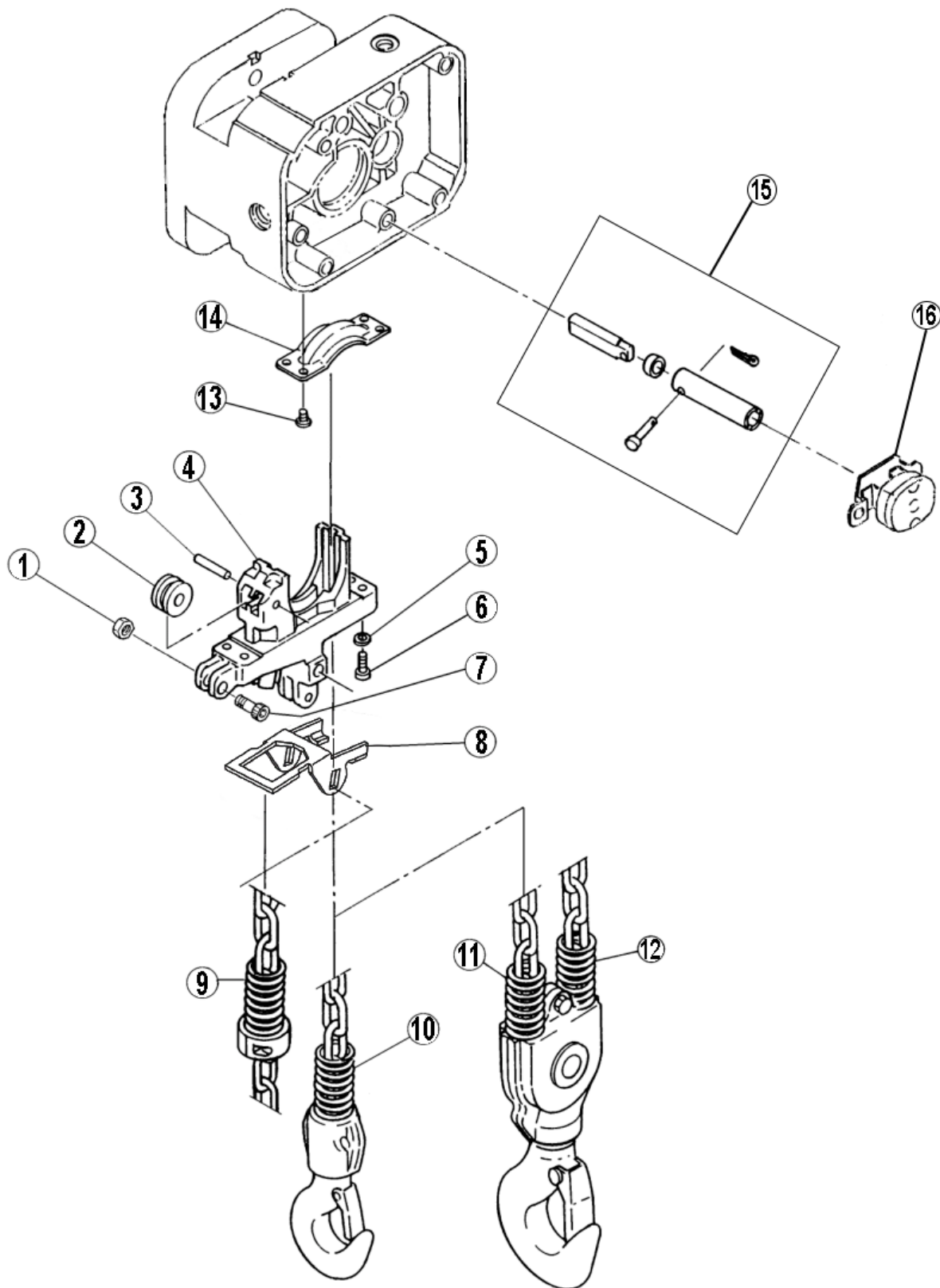

HOIST CHAIN ENTRY & LIMIT SWITCH ASSEMBLY

Diagram D.



PARTS LIST			
PART NO.	PART NAME	PART NO.	PART NAME
1.	NUT	9.	CHAIN END STOP SPRING
2.	CHAIN GUIDE ROLLER	10.	SINGLE FALL BOTTOM HOOK SPRING
3.	ROLLER PIN	11.	TWO FALL BOTTOM HOOK SPRING A.
4.	CHAIN GUIDE CASTING	12.	TWO FALL BOTTOM HOOK SPRING B.
5.	SPRING WASHER	13.	SCREW
6.	SOCKET BOLT	14.	CHAIN GUIDE PLATE
7.	SOCKET BOLT	15.	LIMIT SWITCH SHAFT ASSEMBLY
8.	LIMIT SWITCH PADDLE	16.	MECHANICAL LIMIT SWITCH

MOTORIZED TROLLEY ASSEMBLY

Diagram E.

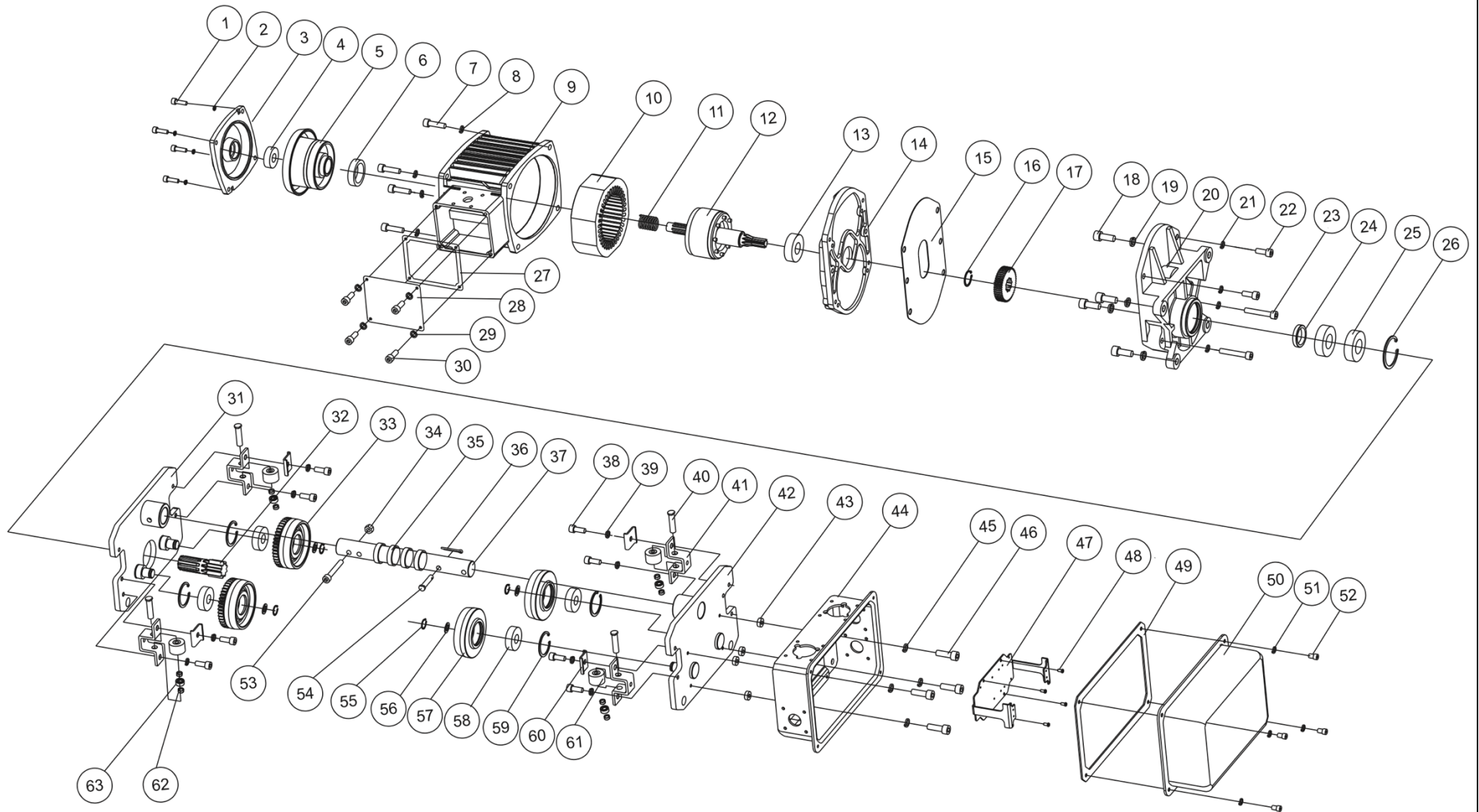

MOTORIZED TROLLEY ASSEMBLY

Diagram E.



PARTS LIST			
PART NO.	PART NAME	PART NO.	PART NAME
1.	SOCKET BOLT	25.	BALL BEARING
2.	SPRING WASHER	26.	CIRCLIP
3.	BRAKE CAP	27.	ELECTRICAL PLATE GASKET
4.	BALL BEARING	28.	ELECTRICAL PLATE COVER
5.	BRAKE ASSEMBLY	29.	SPRING WASHER
6.	SEAL	30.	SOCKET BOLT
7.	SOCKET BOLT	31.	TROLLEY MOTOR ASSEMBLY SIDE PLATE
8.	SPRING WASHER	32.	GEAR SHAFT
9.	MOTOR COVER	33.	GEAR
10.	MOTOR STATOR	34.	SELF-LOCKING NUT
11.	BRAKE SPRING	35.	COLLAR/ SPACER
12.	ROTOR ASSEMBLY	36.	SPLIT PIN
13.	BALL BEARING	37.	TROLLEY SHAFT
14.	MOTOR COVER PLATE	38.	SOCKET BOLT
15.	MOTOR PLATE GASKET	39.	SPRING WASHER
16.	CIRCLIP	40.	ROLLER SHAFT
17.	GEAR	41.	ROLLER WHEEL BRACKET
18.	SOCKET BOLT	42.	TROLLEY ELECTRICAL SIDE PLATE
19.	SPRING WASHER	43.	GASKET
20.	GEAR BOX	44.	ELECTRICAL CONTROL CASE
21.	SPRING WASHER	45.	SPRING WASHER
22.	SOCKET BOLT	46.	SOCKET BOLT
23.	SOCKET BOLT	47.	ELECTRIC CONTROL CASE
24.	CIRCLIP	48.	HEAD SCREWS



PARTS LIST			
PART NO.	PART NAME	PART NO.	PART NAME
49.	ELECTRICAL CONTROL CASE COVER ASSEMBLY	56.	TROLLEY WHEEL WASHER
50.	ELECTRICAL CONTROL CASE COVER	57.	TROLLEY WHEEL
51.	SPRING WASHER	58.	BALL BEARING
52.	SOCKET BOLT	59.	CIRCLIP
53.	SOCKET BOLT	60.	GUIDE ROLLER BRACKET
54.	TROLLEY SHAFT PIN	61.	GUIDE ROLLER
55.	CIRCLIP		

SINGLE SPEED HOIST

Wiring Diagram. 1; 2; 3 & 5 Ton Models



power in	Main Contactor	Up Contactor	Down Contactor	Phase sequence protector	Transformer	Emergency Stop		Pendant Pushbutton	
							Start	Up	Down

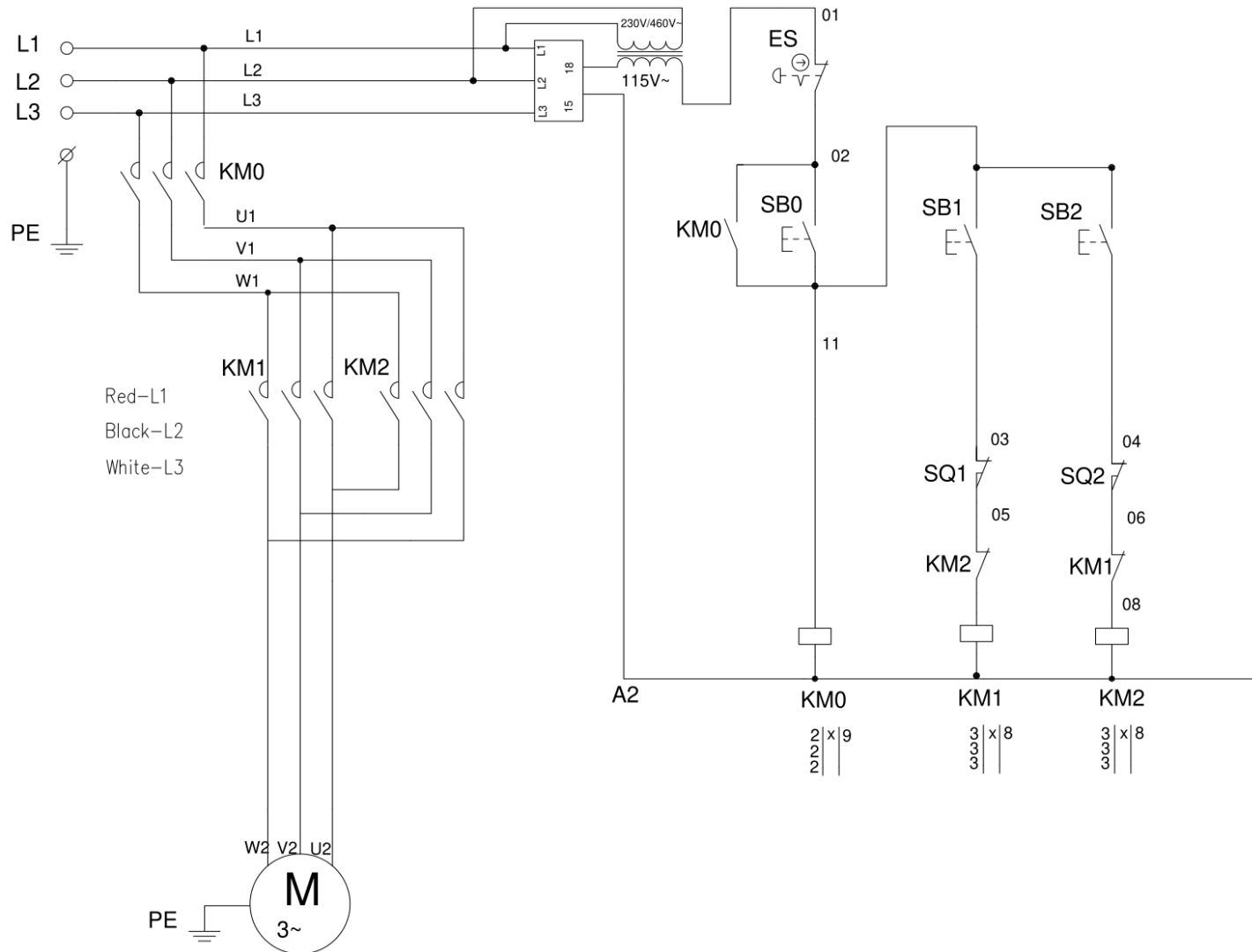

Sign	Name
	Contactor
	Coil
	Normally closed auxiliary contact
	Limit switch
	Emergency stop switch
	Pendant Pushbutton
	Single speed motor
	Transformer
	Phase sequence protector
	Protective Earthing

DUAL SPEED HOIST

Wiring Diagram. 1 Ton Model



power in	Main Contactor	Up Contactor	Down Contactor	Phase sequence protector	Transformer	Emergency Stop	Pendant Pushbutton		
		Fast Contactor				Start Pendant Pushbutton	Up	Down	Fast

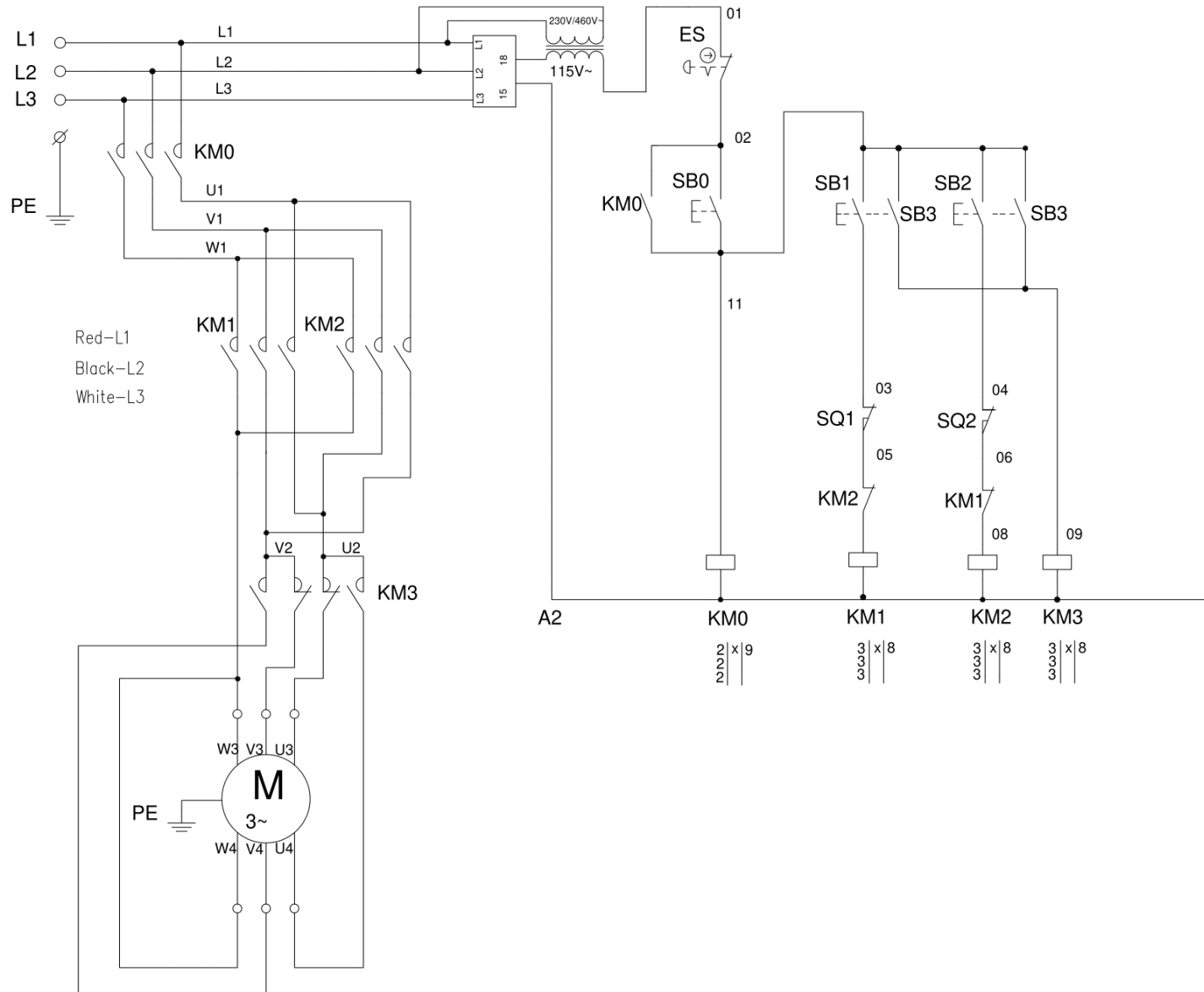

Red-L1
Black-L2
White-L3

Sign	Name
	Contactor
	Coil
	Normally closed auxiliary contact
	Limit switch
	Emergency stop switch
	Pendant Pushbutton
	Dual speed motor
	Transformer
	Phase sequence protector
	Protective Earthing

DUAL SPEED HOIST

Wiring Diagram. 2; 3 & 5 Ton Model



BISON
LIFTING EQUIPMENT

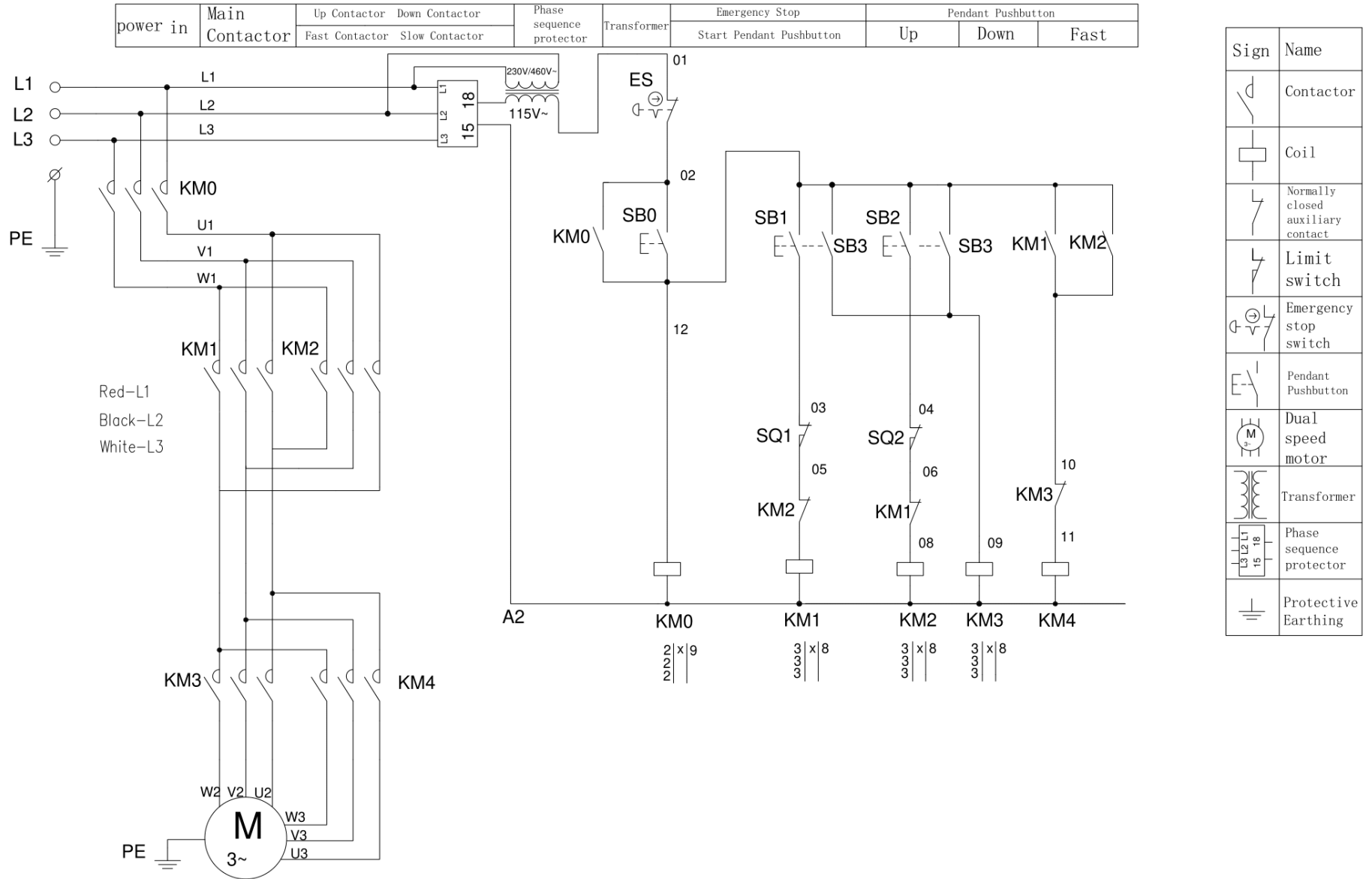

Sign	Name
	Contactor
	Coil
	Normally closed auxiliary contact
	Limit switch
	Emergency stop switch
	Pendant Pushbutton
	Dual speed motor
	Transformer
	Phase sequence protector
	Protective Earthing

SINGLE SPEED HOIST + TROLLEY

Wiring Diagram. 1; 2; 3 & 5 Ton Models



power in supply	Main power	Electric Chain Hoist		Phase sequence protector	Transformer	Main power supply	Foreward up	Reversal down	Foreward left	Reversal right
	power supply	Foreward	Reversal							

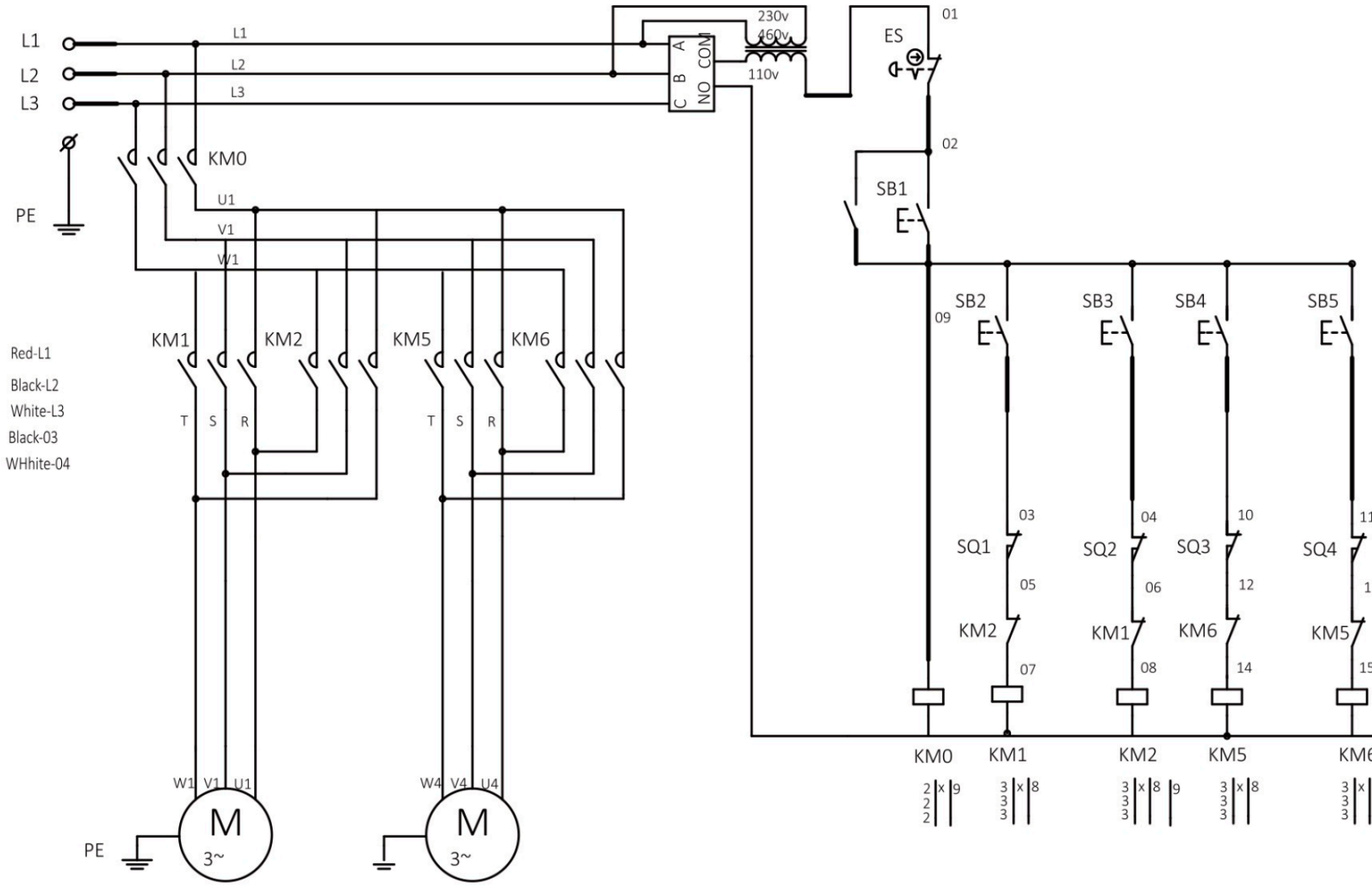

- Red-L1
- Black-L2
- White-L3
- Black-03
- White-04

Sign	Name
	Main contact
	Coil
	Normally closed auxiliary contact
	Limit switch
	Emergency stop switch
	Button switch
	Single speed motor
	Transformer
	Phase sequence protector
	Protective Earthing

DUAL SPEED HOIST + TROLLEY

Wiring Diagram. 1; 2; 3 & 5 Ton Models



BISON
LIFTING EQUIPMENT

