

BVH-050

1/2 TON VARIABLE SPEED SUSPENSION BAR MOUNTED HOIST
1-PHASE 120V

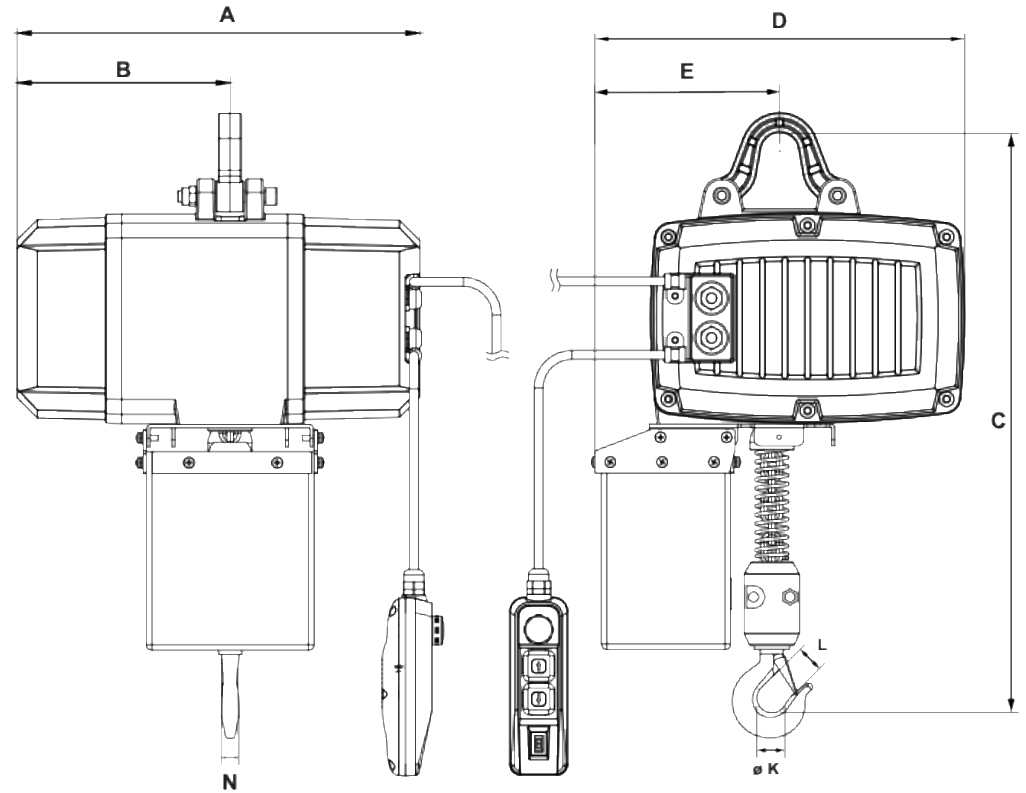

Product Code	Capacity	Standard Lift Height	Push Button Cord	Lifting Speed	Motor Output	Load Chain Size Ø	Chain Fall Lines	Net Weight
	<i>tons</i>	<i>feet</i>	<i>feet</i>	<i>ft/min</i>	<i>hp</i>	<i>mm</i>		<i>lbs.</i>
BVH-050	1/2	16	13	0-33	1.4	Ø 6.3	1	72.6

Product Code	Capacity	Headroom (C)	A	B	D	E	K	L	N	Hoist Current
	<i>tons</i>	<i>inches</i>	<i>inches</i>	<i>inches</i>	<i>inches</i>	<i>inches</i>	<i>inches</i>	<i>inches</i>	<i>inches</i>	120V
BVH-050	1/2	21.1	14.6	7.7	13.4	6.7	1.12	0.76	0.7	15A